



BEDSLIDE  [®]

ASSEMBLY AND INSTALLATION

"S" MODEL

Supplied Hardware: (8) 1/4-20 X 1 1/4" elevator bolts, (8) 1/4-20 serrated nuts, (2) 1/4-20 x 1 1/4" button head bolts (2) fender washers, (2) 1/4-20 nyloc nuts

BEDSLIDE
GET TO IT.



**ASSEMBLY
INSTRUCTIONS**

Tools Needed: 1/2", 7/16", & 9/16" wrenches, 5/32 allen key

STEP 1.

BOLT DOWN COMPOSITE DECK

**The deck halves sit upside down and rest on the BEDSLIDE for shipping purposes.*

Flip one half of deck over, slide under center track and position on BEDSLIDE frame so that the pre-drilled mounting holes on the deck line up with the mounting holes on the frame. Secure each the deck half using (4) of the supplied 1/4-20 X 1 1/4" elevator bolts and (4) 1/4-20 serrated flange nuts. Tighten all flange nuts with a 7/16" wrench.



7/16" WRENCH

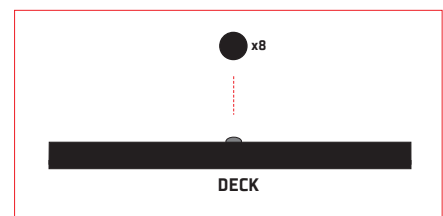
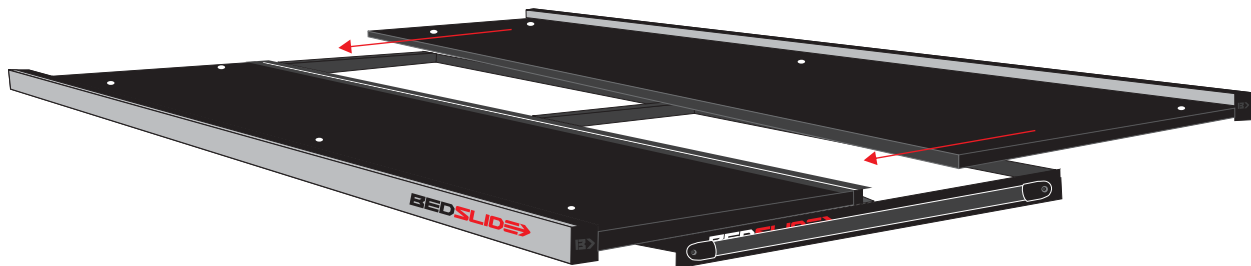

STEP 2.

MOUNT FRONT BEDTRAX

Position front BEDTRAX so that the mount holes line up with the pre-drilled holes on the deck. Secure the BEDTRAX to the deck using [2] of the supplied 1/4-20 x 1 1/4" button head bolts, fender washers, and nyloc nuts. Tighten with a 7/16" wrench and 5/32 allen key.

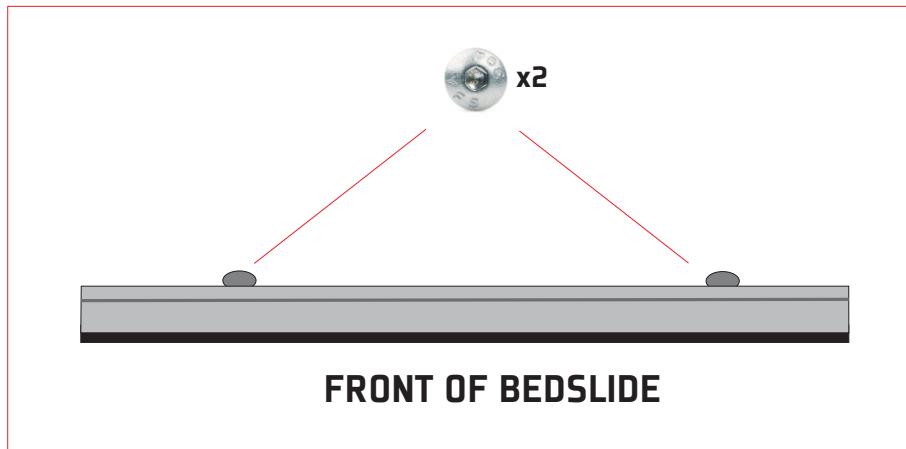

Supplied Hardware: [4] 5/16 riv nuts, [1] riv nut tool,
[4] 5/16 x 2" hex head bolts, [4] 5/16 split lock washers,
[4] 3/8 flat washers

BEDSLIDE
GET TO IT.



**INSTALLATION
INSTRUCTIONS**

Tools Needed: Drill, 1/2" drill bit, sharpie, tape measure,
1/2" socket, ratchet, 1/2" open end wrench

STEP 1.

CENTER BEDSLIDE® IN TRUCK BED & CHECK FITMENT

Place assembled BEDSLIDE® in truck bed. Center between the wheel wells and leave 1 1/2" clearance space between bulkhead and BEDSLIDE® frame. Next make sure tailgate clears the BEDSLIDE® when tailgate is closed and that the BEDSLIDE® does not make contact with tailgate when slid open.

If BEDSLIDE® does not clear the tailgate or has the step in the gate you will need our LIFT BLOCK KIT PART #FPLB1.

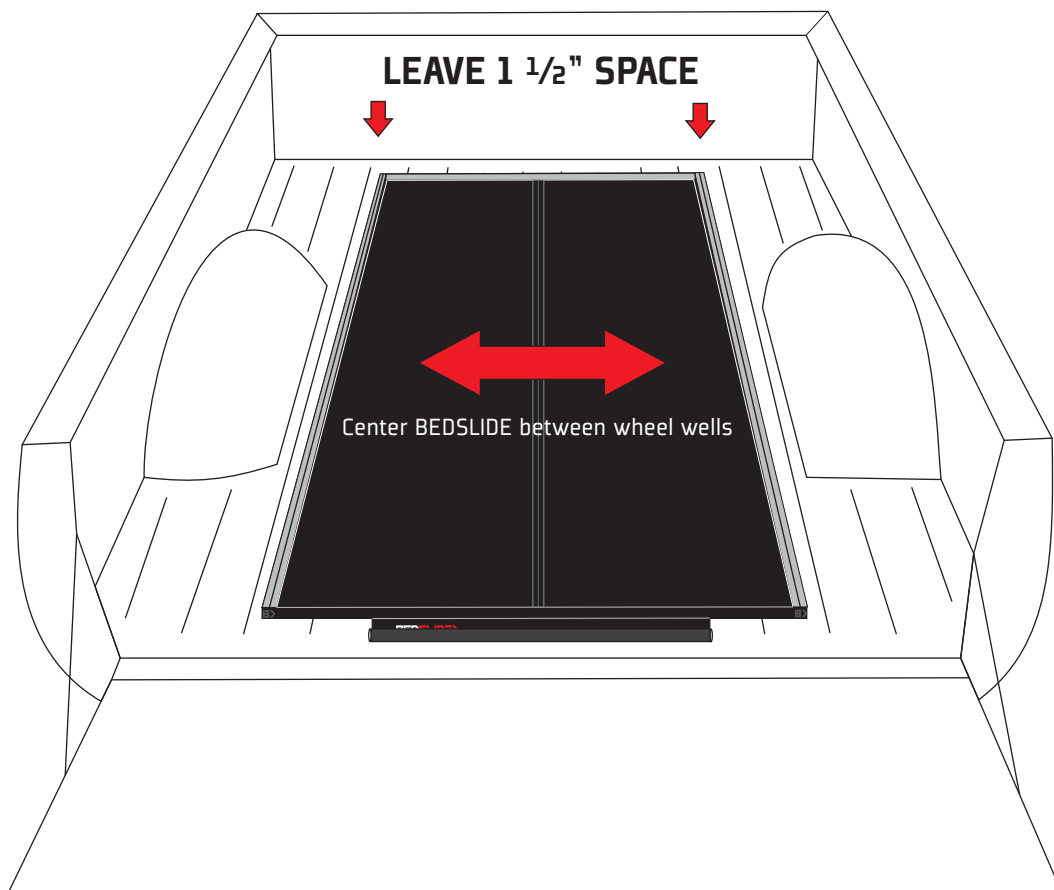

STEP 2.

Slowly move upper tray out from closed position and avoid shifting hole placement. Mark and drill (4) 1/2" mounting holes using the pre-punched holes in the cab end and center cross member. Use the hole that rests on the highest part of the truck bed floor.

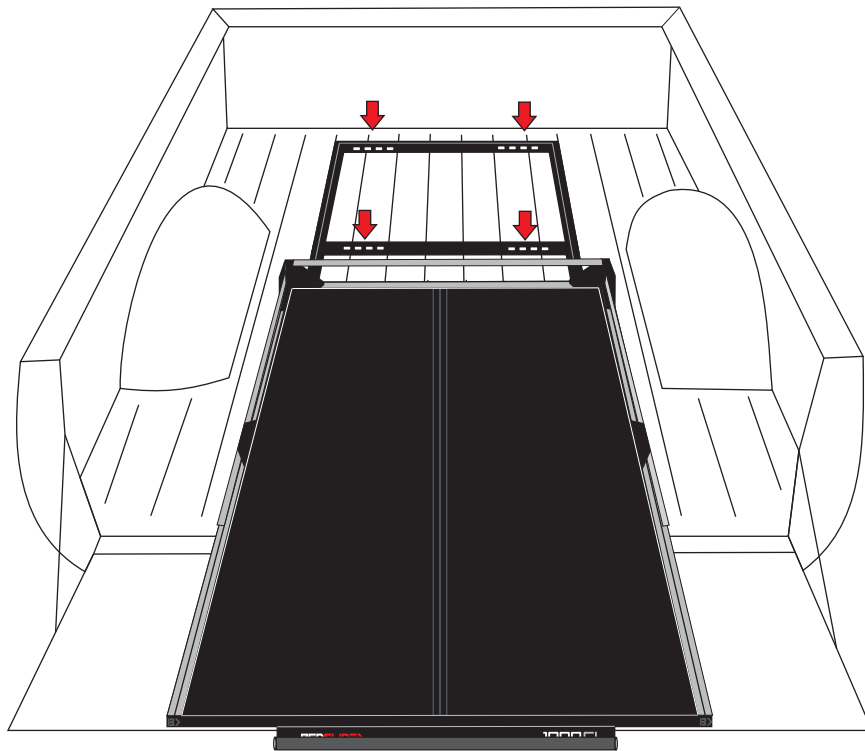

STEP 4.

INSTALL (4) RIV NUTS

Move BEDSLIDE® to access the (4) marked holes for the center cross member and drill through the bed using the 1/2" drill bit. Next, insert a 5/16 bolt through the riv nut tool and into a riv nut. Insert the assembly into a mounting hole. Tighten the bolt while holding the riv nut tool with a 1/2" wrench making sure the assembly sits flush with the bed. As you tighten the bolt the riv nut will compress from underneath and secure to the bed. Repeat to the remaining hole. **Do not over tighten! Do not use air impact tools!**

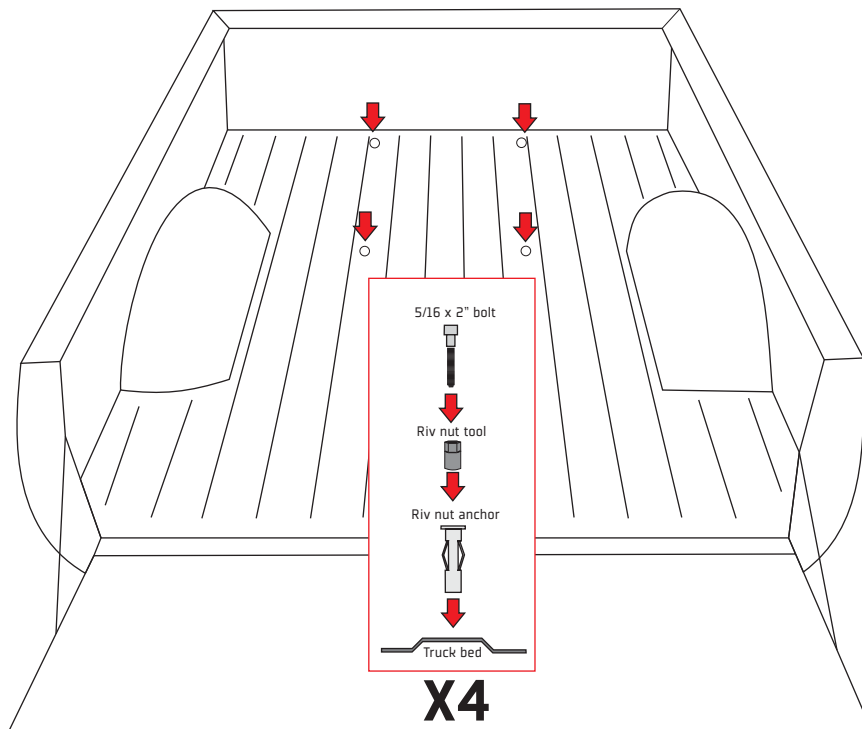

STEP 5.

BOLT DOWN BEDSLIDE®

Re-install BEDSLIDE® in truck bed, align each mount hole with each riv nut in the bed. Bolt down at each mounting location using a 5/16 x 2" bolt.

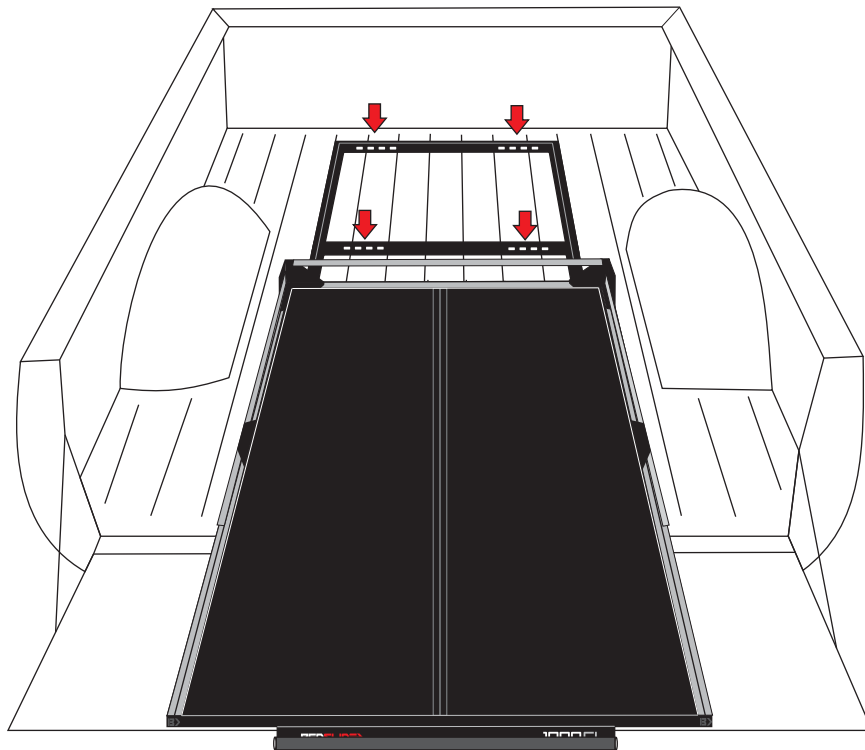

BEDSLIDE 

STEP 6.

PROTECTIVE FILM REMOVAL

Pull a corner of the protective film and slowly pull it away from the die cut decals on each side of the tie down rails.



If the film comes up with a letter attached, position back in place and rub with a card such as a bank card or even your hand so the decal adheres to the surface of the tie down rail.



