

JACKRABBIT SERIES

RETRACTABLE HARD TRUCK BED COVERS



TOYOTA TACOMA SB & TACOMA DOUBLE CAB XSB INSTALLATION INSTRUCTIONS



(800) 338-3697
www.paceedwards.com

Pace Edwards Company
2400 Commercial Blvd.
Centralia WA 98531

TABLE OF CONTENTS

Tools Required for Assembly	2
Before You Start	2
Drain Hole Locations	2
STEP 1: Remove Plywood Packaging	2
Packaging Contents	2
STEP 2: Positioning Canister	3
STEP 3: Installing Rails	3
STEP 4: Repositioning Canister	3
STEP 5: Installing Clamps, Rail Brackets & Pull Strap ..	4
STEP 6: Lubricating & Placing Sweep Seals	5
STEP 7: Installing Drain Tubes	5
STEP 8: Install Top Cover & Velcro	5
Operating Instructions	6
Helpful Maintenance Hints	6

TOOLS REQUIRED FOR ASSEMBLY:

3/8" wrench or socket #2 Phillips screwdriver Side Cut Pliers
7/16" wrench or socket Tape measure 9/64" allen wrench

Note: There should be no drilling into the truck body needed on most standard or full-size trucks .

BEFORE YOU START:

Read the instructions carefully before you start. These instructions are written for one-person installation. We have noted where briefly having an extra person's assistance can make installation easier. If you have questions regarding the installation please call our Technical Support Line at (800) 338-3697.

DRAIN HOLE LOCATIONS:

The JackRabbit is designed to carry rainwater from the cover into the canister and then out through the drains. Most truck models have standard OE drain holes or plastic/rubber access ports in the front of the truck bed. Check to make sure your truck has the OE drain holes so that drilling into the sheet metal is not required. If drilling is necessary, be sure to check the underside of the truck bed for the best location. The holes should be located near the side and as far forward as possible. Use a drill bit suitable for sheet metal (such as a taper drill or step drill). Drill drain tube clearance holes at 3/4" (19mm). This will need to be done before installing the cover.

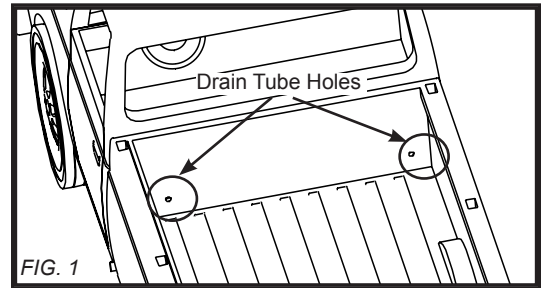

STEP 1: REMOVE PACKAGING PLYWOOD & HARDWARE

Remove the canister from the box. Using the 3/8" wrench or socket remove the 2 bolts holding the plywood on the ends of the canister. Use Side Cut Pliers to cut handle retaining straps.

DISCARD PLYWOOD PACKAGING AND BOLTS!

CAUTION!

DO NOT USE A KNIFE TO OPEN THE RAIL BOX. OPEN THE RAIL BOX ALONG THE LENGTH OF THE BOX AND LIFT RAILS OUT TO AVOID SCRATCHING THE SURFACE OF THE RAILS ON THE PACKAGE STAPLES.

CAUTION!

PACKAGING CONTENTS:

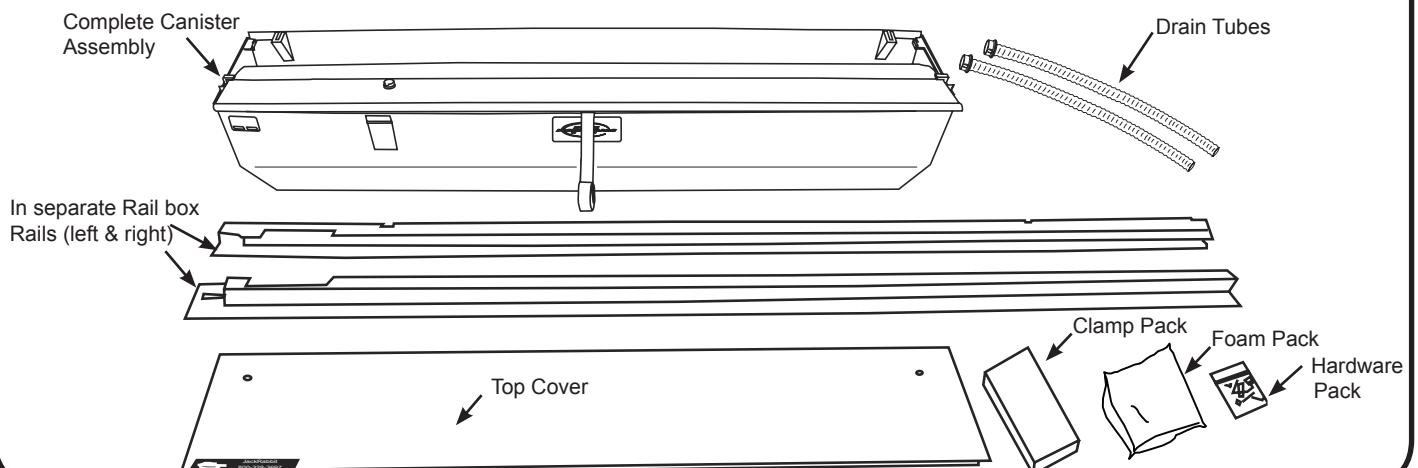



IF YOU HAVE ANOTHER PERSON TO HELP STEADY THE CANISTER, IT MAY BE EASIER TO INSTALL THE RAILS (DESCRIBED IN STEP 3) BEFORE POSITIONING THE CANISTER IN THE TRUCK BED.



STEP 2: POSITIONING CANISTER

Remove the top cover from the canister box and set it aside for later installation.

Perform a quick inventory to insure all parts are there. Be sure to check inside the small cardboard box for parts.

You will need one or two support pieces (We suggest using the top of the box the Jackrabbit was shipped in.) to set in the truck bed approximately one foot from the cab that will go under the canister, raising the top of the canister above the bed rails by 2-3 inches.

Remove the Canister from the box and set it on the support(s) in the truck bed.

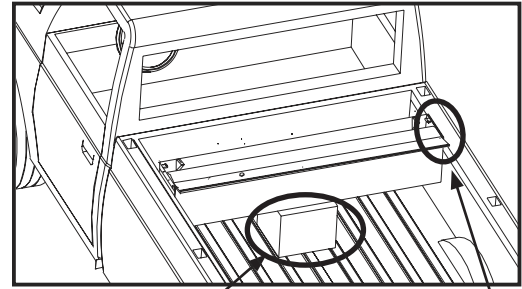

Support Piece Top of Canister should clear Truck Bed Rails by 2-3"

STEP 3: INSTALLING RAILS

HARDWARE USED:



1/4-20 x 3/4" BOLT x 2



1/4" LOCK WASHER x 2



1/4" FLAT WASHER x 2

Open the rail box along the length of the box; lift rails out to avoid scratching the rail surface on the package staples.

REMOVE PROTECTIVE PAPER FROM THE FOAM ON THE UNDERSIDE OF RAILS. THIS IS FOR PACKAGING PURPOSES ONLY.

Install the rails by angling them around the attached blanket guides on the canister, threading the blanket in the rails, and sliding the rails into the rail grips that are attached on the inside of the canister.

Then slide the rails forward, towards the truck cab making sure that both of the rail grips are engaged. (Figure 3a)

Secure the rail by installing the hardware (Bolt, Lock Washer, Flat Washer) through the Rail Grip Attachment and predrilled hole in the rail.

Complete for both left and right rails.

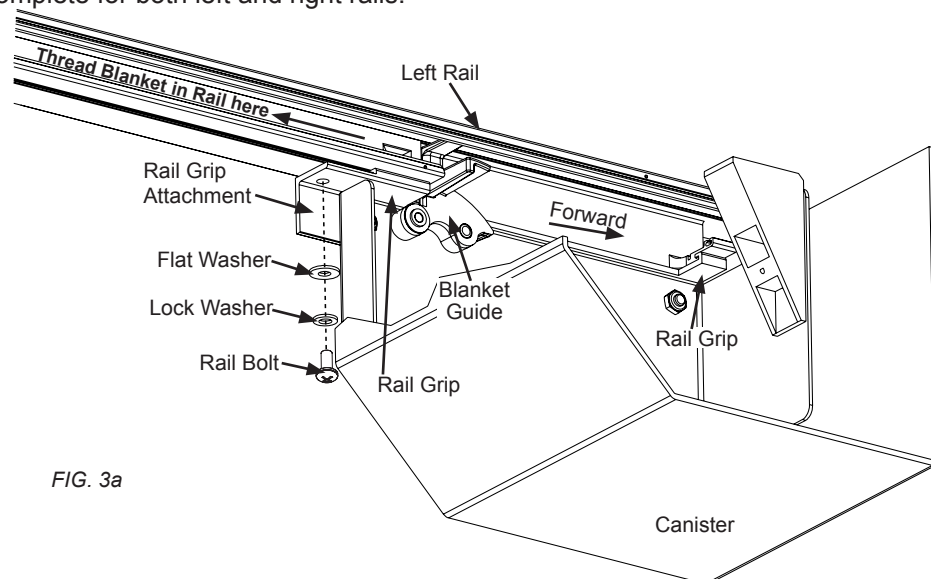

FIG. 3a

STEP 4: REPOSITIONING CANISTER

Remove the support(s) under the canister so that the canister and rails rest firmly on the sides of the truck bed. With the tailgate closed position the rails so they are snug up against the tailgate.

STEP 5: INSTALLING CLAMPS, RAIL BRACKETS & PULLSTRAP

HARDWARE USED:

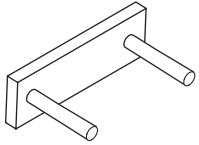

INNER RAIL CLAMP x 4

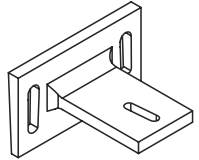

OUTER ANGLED RAIL CLAMP x 4 (NARROW EDGE GOES DOWN!)

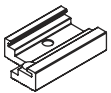

RAIL CLAMP BRACKET A x 2

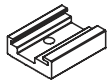

RAIL CLAMP BRACKET B x 2



1/4" FLAT WASHER x 12



1/4" LOCK WASHER x 12



1/4-20 x 5/8" BOLT x 8



RAIL CLAMP NUT x 8

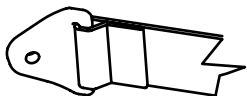

PULL STRAP x 1 (TAILGATE END)

Slide the four (4) Inner Rail Clamps (2 on each side) through the Tie Down Bars of the truck. Place the Outer Angled Rail Clamps on the Inner Rail Clamps (**MAKE SURE THE NARROWER EDGE IS DOWN ON THE OUTER ANGLED RAIL CLAMPS**) loosely fasten the clamps in place with the 1/4" Washer, 1/4" Lock Washer and Rail Clamp Nut on both sides of the truck bed.

The first clamp should be placed about 6 inches from the canister (closest to truck cab).

The second clamp assembly should be about 4 inches from the end of the Tie Down Bar (closest to the tailgate).

Slide Rail Clamp Bracket A on each Rail followed by Rail Clamp Bracket B.

Rail Clamp Bracket A should be closest to the Cab of the truck.

At this time you will need to install the tailgate end of the pull strap to the underside of the drivers side rail using the #8-32 x 3/4 machine screw that is already installed at the tailgate end on the underside of the rail. (Figure 5A)

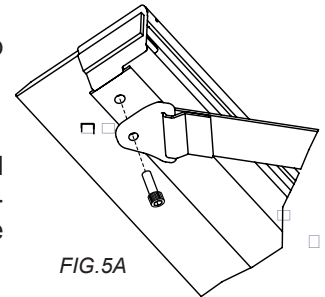

FIG.5A

Now, loosely assemble the Rail Clamp Brackets to the Outer Angled Rail Clamps with the 1/4" Washer, 1/4" Lock Washer and 1/4-20 x 1/2" Bolt on each side of the truck bed.

Center the Rails in the Truck bed.

Check that the spacing [BR] between the Left and Right Rails, as shown below:

Note: Part number is on the serial number label in the upper left corner of the canister (looking from tailgate).

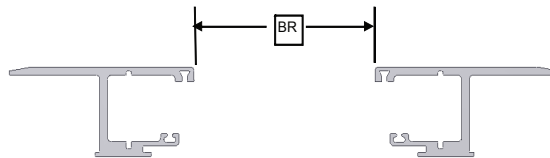

PART NUMBER	BETWEEN RAILS (BR)
FM and TR2035	50 5/16
FM and TR2074	51 13/16
FM and TR2109	50 5/16
FM and TR2110	51 13/16

Once correct spacing is achieved tighten **ONLY** the Rail Clamp Brackets A & B in place.

With the Tailgate in the closed position correct spacing to the tailgate should be 1/16" to prevent the tailgate from striking the side rails when closing.

Tighten the Set Screws on both Rail Clamp Bracket A to hold rails in position. (*Adjust spacing from the tailgate by moving rails forward or backward as needed prior to final tightening of set screws.*)

Apply downward pressure while tightening the Outer Angled Rail Clamp to the Inner Rail Clamp, especially on the tailgate end. This will ensure a tight seal, firm seat, and good fit on the truck bed.

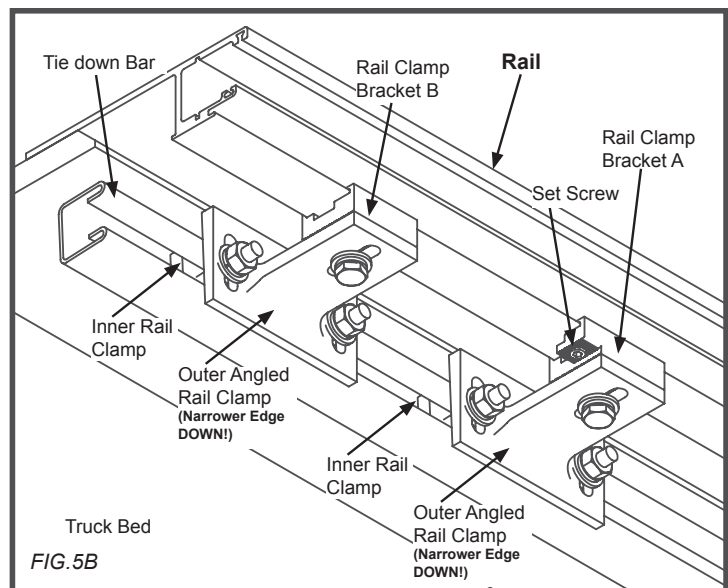

FIG.5B

STEP 6: LUBRICATING & PLACING THE SWEEP SEALS

Locate the sweep seals (rubber weather strips) on the rails. Use the provided UV protectant to wipe the underside of the sweep seal and the top of the wear strip on each rail. The UV protectant can be found adhered to the underside of the top cover lid or in the hardware pack.

Extend the cover to the tailgate. Use an Allen Wrench if needed to carefully draw out the sweep seal (seal should be angled outwards toward the cover—not rolling in toward the bed rail). (Fig 6A)

Proper care and placement of the sweep seal will ensure smooth operation of the cover. Alcohol, petroleum or silicone based cleaners should be avoided and ARE NOT recommended for our covers.

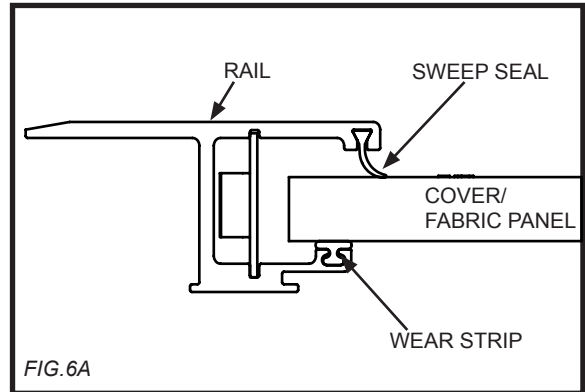

STEP 7: INSTALLING DRAIN TUBES

First ensure that the “o” ring is in place on the drain tube end being inserted into the canister (This will prevent water leakage). Test fit the drain tube to determine the length you want to trim it. Always caution on the long side. Trim the end that will be inserted through the truck bed with the wire cutters or a utility knife.

With the cover *opened*, insert the drain tube fittings into the pre-drilled holes on the underside of the canister by pushing them in place from under the canister. Drain tube should click into place.

Place the other end of the drain tube through the plastic/ rubber access port or through the pre-drilled holes in the floor or the front wall of the truck bed.

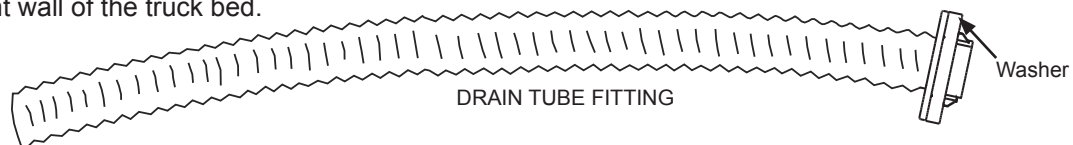

NOTE: If the OE access ports are located on the front wall of the truck bed you should ensure that the drain-tubes are inserted and directed down so water flows out of the truck.

STEP 8: ATTACHING TOP COVER & VELCRO TO PULL STRAP

HARDWARE USED:



ALCOHOL WIPE x 1

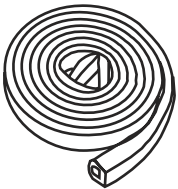

“D” SHAPED or FLAT ADHESIVE BACK FOAM x 1



4” VELCRO STRIP x 1



BLACK TOP COVER SCREW x 2

Clean and prep the surface of the truck bed just behind the cab with the alcohol wipe provided. Attach “D” shaped, or Flat, adhesive backed foam. This will provide a seal between the front of the top cover and the front of the truck bed.

Place the Top Cover on the canister and install with the two black Top Cover screws into the top cover mounting blocks. (we recommend that you use a threadlocking adhesive like Loctite® on the screws)

Retract the cover to the fully open position.

Attach the 4” Velcro strip onto the Velcro strip already attached to the pull strap.

Pull the pull strap over to the driver’s side rail and remove the tape from the 4” Velcro strip.

Then apply the Velcro strip onto the underside of the rail at your desired position.

This will hold the pull strap off of the floor and out of the way when cargo is being stored in the truck bed.

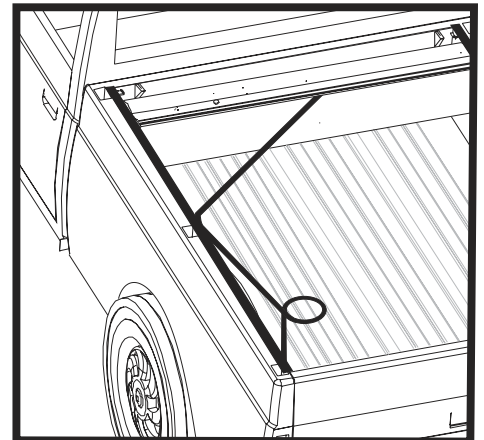

You have now completed the installation of your JackRabbit hard tonneau cover. If you have any questions please do not hesitate to call us at: (800) 338-3697 and ask for our technical service department.

OPERATING INSTRUCTIONS

1. To open the cover, turn the actuator knob clockwise 90° until it clicks in the open position. This retracts the latches into the handle and the cover is free to roll open into the canister. A tug on the pull strap will release the latch and allow the cover to lock into the rails.
2. To latch the cover in one of the mid-range positions, pull it back just beyond the position desired and allow the cover to retract until it latches into place. Latching positions are located every 12 inches along the rails. The clicking sound is the spring-loaded latches mounted inside the handle. The latches are designed to bypass the latching positions as the cover is being closed and to stop the cover as it is being retracted.
3. To close the cover, pull on the strap to draw it back toward the tailgate. When it is within easy reach, grasp the handle by the handgrip and pull the cover to the latching position against the tailgate.
4. To use the key lock, position the cover on the truck bed with the actuator knob in the closed position and turn the key.

HELPFUL MAINTENANCE HINTS

To help keep the JackRabbit Series tonneau cover looking its best, we recommend washing it the same as caring for your truck finish. However, you should not wax your cover. Using a citrus-based vinyl cleaner and UV Protectant will keep your cover looking like new.

To assure quiet, smooth operation, periodically apply a generous amount of UV Protectant to a rag and wipe out the inside of the rails, the underside of the sweep seals, and the top of the wear strips. Repeat as needed until these components are cleaned of debris and well lubricated.

Ensure proper placement of the sweep seal as shown in Step 7. Re-apply protectant/lubricant if the cover begins squeaking or sticking during use. (Fig 1).

Alcohol, petroleum or silicon based cleaners should be avoided and ARE NOT recommended for our covers.

It is important to open and close the cover regularly. The spring that operated the cover is self-lubricating and regular use assures that it stays in proper working condition.

Periodically remove the Top Cover and clean out the inside of the canister.

Drain tubes may become clogged overtime and should be removed and cleaned. To remove the Drain Tubes reach under the canister, grab the Drain Tube Fitting and turn it while applying light downward pressure. When the retaining tabs align with notches in the bottom of the canister the Drain Tube and Fitting will drop out.

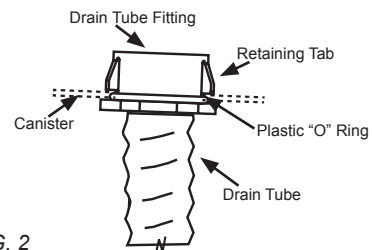
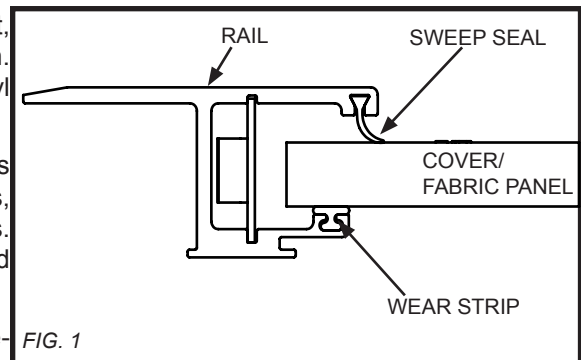

**ULTRAGROOVE™ METAL
FULL-METAL™ JACKRABBIT®
FULL-METAL JACKRABBIT MATTE
ULTIMATE LIFETIME WARRANTY**

This limited lifetime warranty covers: Failure of materials and workmanship. Warranty replacement will be issued at no cost for the life of the cover to the original owner on original vehicle – nontransferable.

- Separation of the UltraGroove Metal/Full Metal JackRabbit/ Full Metal JackRabbit Matte deck panels
- All lock assemblies
- All hardware and components

**ULTRAGROOVE ELECTRIC
BEDLOCKER® /BEDLOCKER MATTE**

For a period of seven (7) years from the date of purchase the Pace Edwards electric retractable cover has the following limited warranty:

- Failure of materials and workmanship
- Separation of the UltraGroove Electric/BedLocker/ BedLocker Matte deck panels
- Failure of the UltraGroove Electric/BedLocker/BedLocker Matte drive system and electrical components
- All hardware and components
- Warranty will be prorated after five (5) years

**ULTRAGROOVE
JACKRABBIT/JACKRABBIT MATTE**

For a period of five (5) years from the date of purchase, the cover will have the following limited warranty:

- Delamination of the ArmorTek deck
- Failure of the Continuous Tension Spring
- All lock assemblies
- All hardware and components

SWITCHBLADE™/SWITCHBLADE METAL

For a period of two (2) years, the cover will have the following limited warranty:

- Delamination of the ArmorTek deck material
- Failure of the Continuous Tension Spring
- All hardware and components

EXCLUSIONS (ALL MODELS):

- Normal wear and tear over the life of the Pace Edwards cover (including fading or discoloration)
- Water intrusion at any location or any damage caused as a result
- Additional installed parts and accessories
- Acts of nature such as tornadoes or hurricanes, or other external causes

ITEMS WHICH WILL VOID WARRANTY:

- Use of lubrication other than prescribed in owners/ installation manual
- Misuse, negligence, or accident
- Improper installation of product
- Failure to adequately secure cargo to prevent damage to the Pace Edwards cover
- Installation of parts or accessory which may interfere with the Pace Edwards cover without written permission of Pace Edwards

CONDITIONS AND LIMITATIONS:

- Any part of the Pace Edwards retractable cover found to be defective under the terms of the warranty will be repaired or replaced, at the discretion of Pace Edwards.
- Pace Edwards will have the final decision if the part in question is defective.
- Pace Edwards has no responsibility with regards to installation by its dealers or agents.
- Pace Edwards does not, under any circumstances, assume responsibility for loss of item, revenue, inconvenience, or other consequential damage including, but not limited to, expenses for telephone, food, lodging, travel, loss, or damage to the vehicle the cover is installed upon, or loss or damage to personal property of the purchaser or user of the product.
- Pace Edwards will not accept any responsibility to any purchaser for warranty expressed or implied by any of its dealers, distributors, or agents.
- Pace Edwards reserves the right to make changes in the design of, improvements to, or warranty of its products without imposing any obligation for any products manufactured.
- Under no circumstances will Pace Edwards be liable for special, indirect, incidental, or consequential damages incurred in connection with any Pace Edwards retractable cover or its accessories.

Effective February 20,2023

WARRANTY REGISTRATION: Please return this form within 14 days of purchase to:
PACE-EDWARDS • Attn: Warranty Dept. • 2400 Commercial Blvd. • Centralia, WA 98531
OR register online at www.pace-edwards.com

Name _____

Address _____

City _____ State _____ Zip _____

Vehicle Year _____ Make _____ Model _____

Model Number _____ Serial Number _____

Email _____ Phone _____

Date of Purchase _____ Purchased From _____ Price Paid _____

Customer Signature _____

2400 Commercial Blvd, Centralia, WA 98531 USA
(360) 736-9991 (main) ♦ (360) 736-9992 (fax)
(800) 338-3697 (toll-free)
www.paceedwards.com

Thank you for choosing products by...

