

INSTALLATION INSTRUCTIONS TOYOTA TACOMA

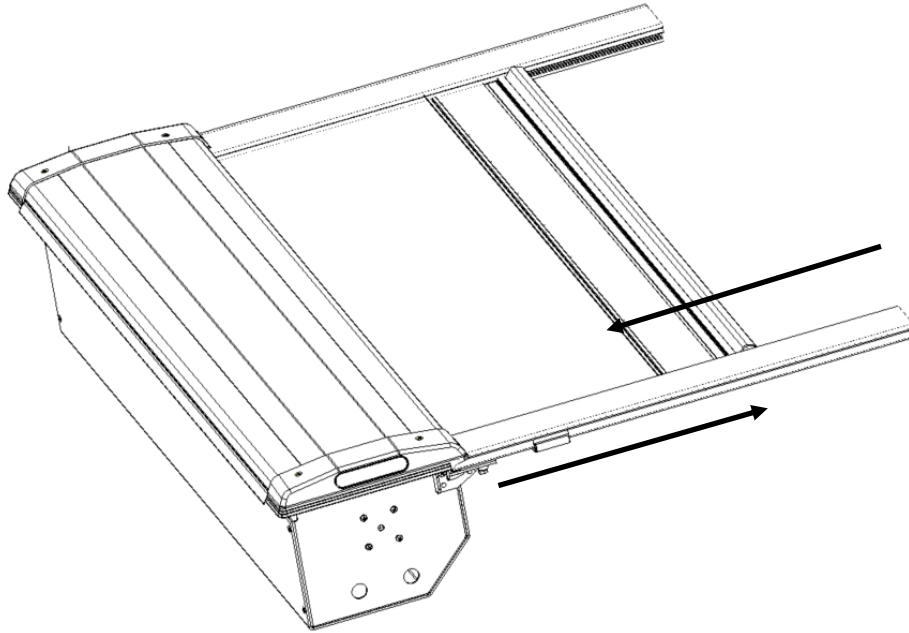

Questions? Comments?
Please send LEER Tonneau
Covers a direct message
through Amazon
We are always here to help!

TABLE OF CONTENTS

Tools Required for Assembly	2
Before You Start	2
Drain Hole Locations	2
STEP 1: Remove From Packaging, and Hardware and Packaging Contents	2
STEP 2: Positioning Canister	3
STEP 3: Installing Rails	3
STEP 4: Installing Clamps.....	3
STEP 5: Attaching the Pull Strap.....	4
STEP 6: Lubricating & Placing Sweep Seals	5
STEP 7: Installing Drain Tubes.....	5
STEP 8: Install Top Cover & Velcro	5
Operating Instructions	6
Maintenance	6
Warranty Statement.....	7

TOOLS REQUIRED FOR ASSEMBLY

7/16" Wrench or Socket

Tape Measure

Side Cut or Needle Nose Pliers

#2 Phillips Screwdriver

Utility Knife

Note: There should be no drilling into the truck body needed on most standard or full-size trucks.

BEFORE YOU START!

Read the instructions carefully before you start. If you have any questions regarding the installation please call our Technical Support Line at: (866) 419-4932

DRAIN HOLE LOCATIONS:

This tonneau cover is designed to carry rainwater from the cover into the canister and then out through the drains. Most truck models have standard OE drain holes or plastic/rubber access ports in the front of the truck bed. Check to make sure your truck has the OE drain holes so that drilling into the sheet metal is not required. If drilling is necessary, be sure to check the underside of the truck bed for the best location. The holes should be located near the side and as far forward as possible. Use a drill bit suitable for sheet metal (such as a taper drill or step drill). Drill drain tube clearance holes at 3/4" (19mm). This will need to be done before installing the cover.

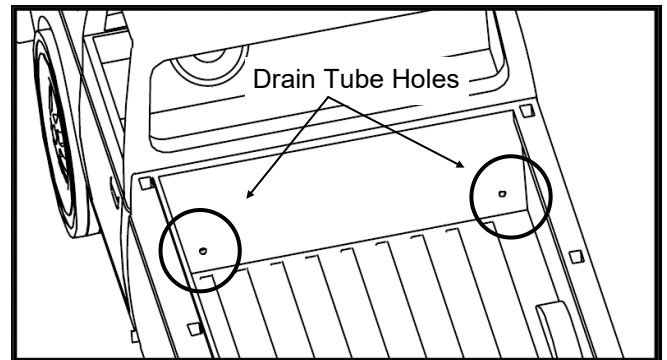

STEP 1: REMOVE FROM PACKAGING AND REVIEW CONTENTS

Unpack the Top Cover, Canister, Rails, Clamp Pack, and Hardware Pack from the canister box. Perform a quick inventory of the packaging contents to insure all parts are there.

CAUTION!

TO AVOID SCRATCHING ANY PARTS PLEASE CUT THE TAPE FROM THE FOAM PACKAGING WITH SCISSORS AND UNWRAP THEM ON A SOLID SURFACE E.G. THE DECONSTRUCTED BOX YOU JUST EMPTIED

CAUTION!

PACKAGING CONTENTS:

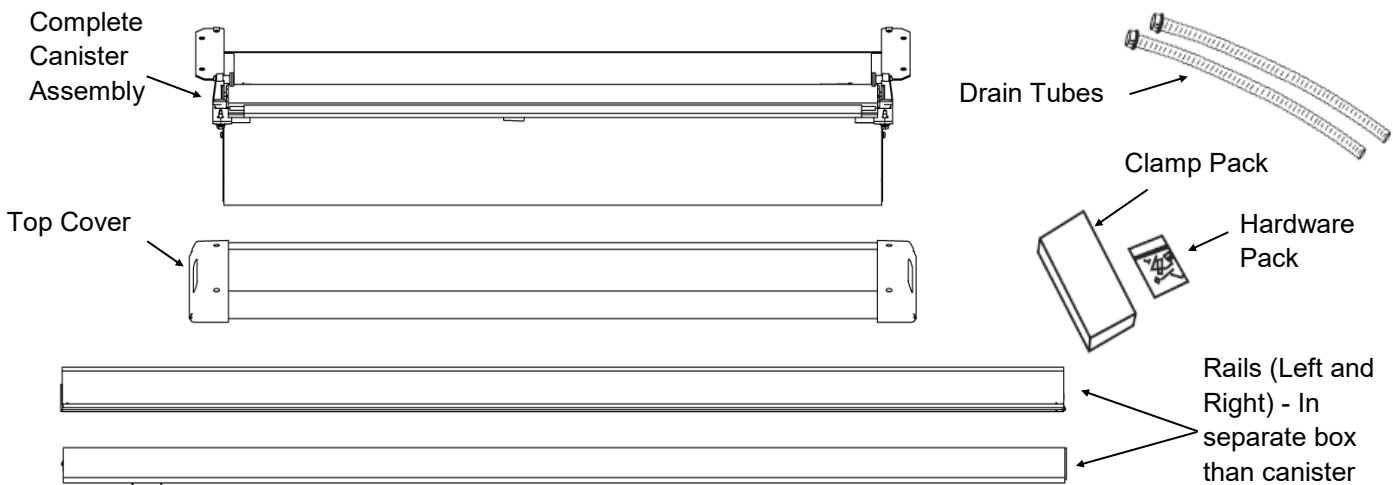

STEP 2: POSITIONING CANISTER

Use the Pull Strap and one canister flange to lift and steady the unit. Wrap the Pull Strap around the center of the canister a couple times and double it up in your hand.

Place the Canister in truck bed just behind the cab and center it from side to side. **Note:** Ensuring that the canister is centered in the bed will help assemble the rails to canister in the next step.



FIG. 2A

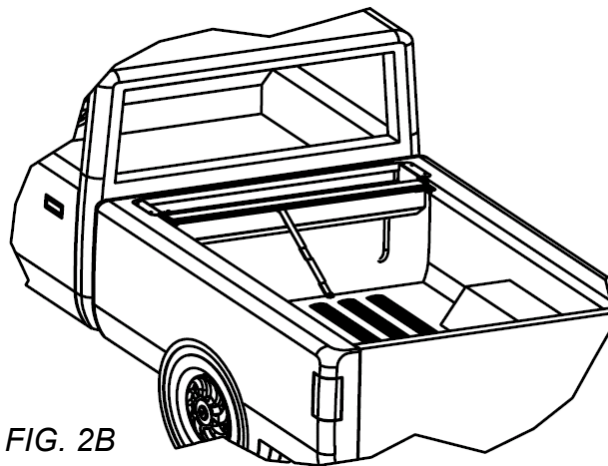

FIG. 2B

STEP 3: INSTALLING RAILS

HARDWARE
USED:



1/4-20 X 1"
RAIL BOLT x 2



1/4" LOCK
WASHER x 2



1/4" FLAT
WASHER x 2

Remove the protective paper from the foam on the underside of the Rail flanges. This is for packaging purposes only. The rails shipped with plastic shims pre-installed to the Rail Brackets for proper spacing. Ensure those shims are in place.

Next identify the left and right side rails. The plastic rail endcap should be towards the tailgate while the rail flange and foam, shims and brackets towards the outside of the truck bed. Install the rails by first guiding the Handle Assembly into the open channel of the rail and then sliding the rail against the blanket guide on the canister. Attach the rail to the canister using the rail bolt, lock washer and flat washer through the blanket guide and into the bottom of the rail.

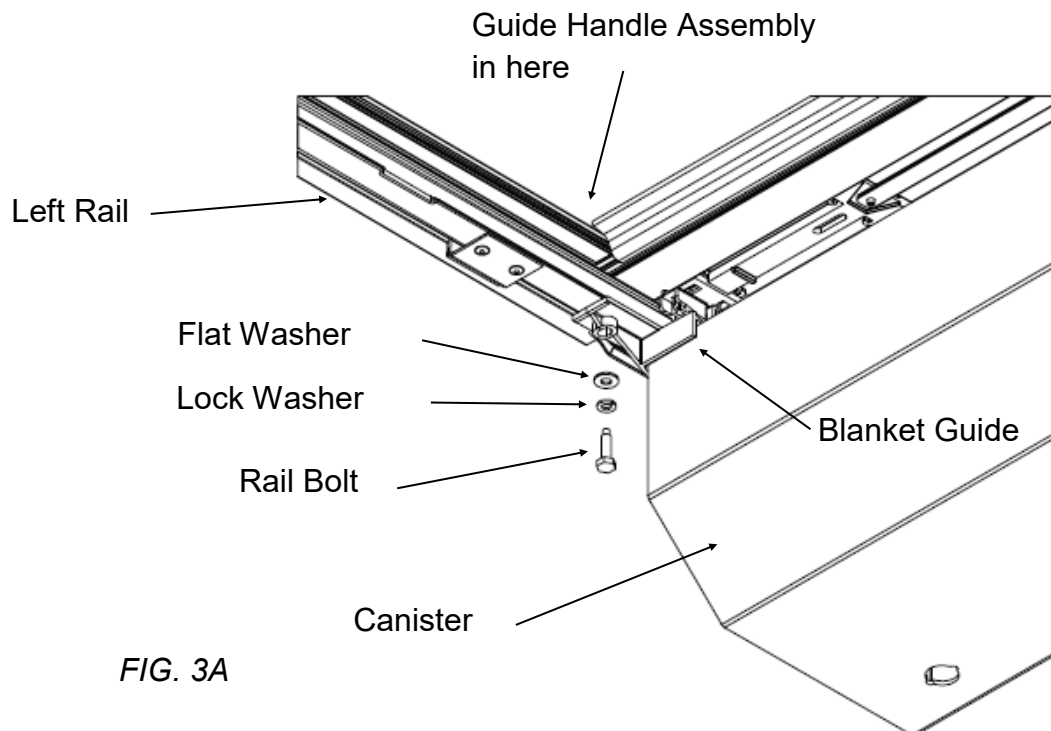
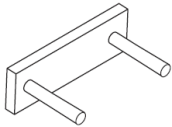

FIG. 3A

The Rail shown is for REFERENCE and may not exactly match your particular Rail geometry.

STEP 4: INSTALLING CLAMPS, RAIL BRACKETS & PULLSTRAP

HARDWARE USED:



INNER RAIL CLAMP x 4

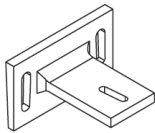

OUTER ANGLED RAIL CLAMP x 4 (NARROW EDGE GOES DOWN!)

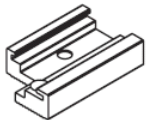

RAIL CLAMP BRACKET A x 2

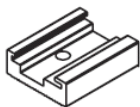

RAIL CLAMP BRACKET B x 2



1/4" FLAT WASHER x 12



1/4" LOCK WASHER x 12



1/4-20 x 5/8" BOLT x 8



RAIL CLAMP NUT x 8

Slide the four (4) Inner Rail Clamps (2 on each side) through the Tie Down Bars of the truck.

Place the Outer Angled Rail Clamps on the Inner Rail Clamps (MAKE SURE THE NARROWER EDGE IS DOWN ON THE OUTER ANGLED RAIL CLAMPS). Fasten the clamps in place with the 1/4" Washer, 1/4" Lock Washer and Rail Clamp Nut on both sides of the truck bed. Tighten the nuts by hand to allow the clamps to slide into place.

The first clamp should be placed about 6 inches from the canister (closest to truck cab).

The second clamp assembly should be about 4 inches from the end of the Tie Down Bar (closest to the tailgate).

Slide Rail Clamp Bracket A on each Rail followed by Rail Clamp Bracket B.

Rail Clamp Bracket A should be closest to the Cab of the truck.

Now, loosely assemble the Rail Clamp Brackets to the Outer Angled Rail Clamps with the 1/4" Washer, 1/4" Lock Washer and 1/4-20 x 1/2" Bolt on each side of the truck bed.

Center the Rails in the Truck bed.

Check that the spacing [BR] between the Left and Right Rails, as shown below:

Note: Part number is on the serial number label in the upper left corner of the canister (looking from tailgate).



FIG. 4A

PART NUMBER	BETWEEN RAILS (BR)
SW2110	51 13/16

Once correct spacing is achieved tighten ONLY the Rail Clamp Brackets A & B in place.

With the Tailgate in the closed position correct spacing to the tailgate should be 1/16" to prevent the tailgate from striking the side rails when closing.

Tighten the Set Screws on both Rail Clamp Bracket A to hold rails in position. (Adjust spacing from the tailgate by moving rails forward or backward as needed prior to final tightening of set screws.)

Apply downward pressure while tightening the Outer Angled Rail Clamp to the Inner Rail Clamp, especially on the tailgate end. This will ensure a tight seal, firm seat, and good fit on the truck bed.

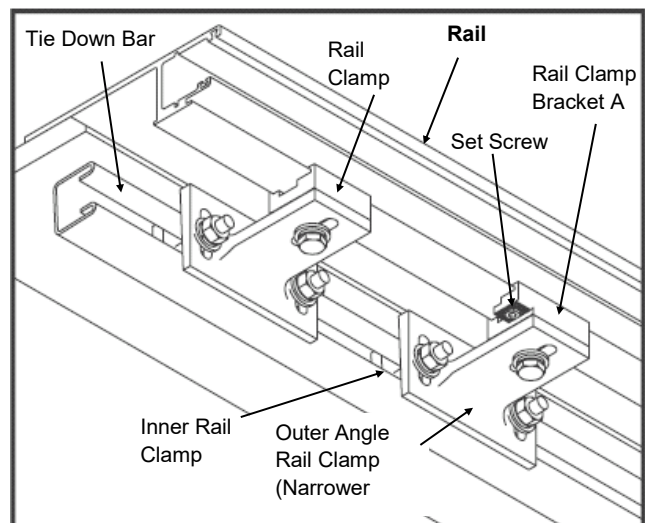

STEP 5: ATTACH THE PULL STRAP

Attach your pull strap to either of the clamps (left or right-hand side) at the tailgate end of the rails by looping it through the assembly and pressing the two velcro strips together. This will ensure the pull strap will always be in easy reach when trying to close the cover.

STEP 6: LUBRICATING & PLACING THE SWEEP SEALS

Locate the sweep seals (rubber weather strips) on the rails. Use the provided UV protectant to wipe the underside of the sweep seal and the top of the wear strip on each rail. The UV protectant can be found adhered to the underside of the top cover lid or in the hardware pack.

Extend the cover to the tailgate. Use an Allen Wrench if needed to carefully draw out the sweep seal (seal should be angled outwards toward the cover—not rolling in toward the bed rail). (Fig. 6A)

Proper care and placement of the sweep seal will ensure smooth operation of the cover. Alcohol, petroleum or silicone based cleaners should be avoided and ARE NOT recommended for our covers.

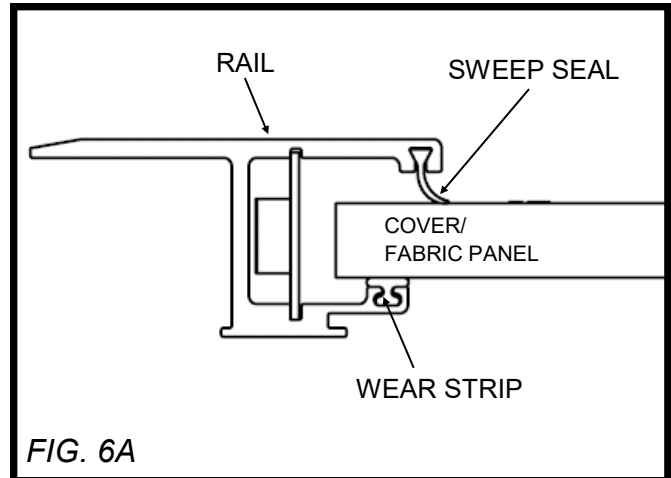

STEP 7: INSTALLING DRAIN TUBES

First, ensure that the Foam Washer is in place on the Drain Fitting as this washer will help prevent water leakage. Next, test fit the drain tube to determine the length you want to trim it. Always caution on the long side. Trim the end that will be inserted through the truck bed using the wire cutters or a utility knife.

With the cover *opened*, insert the drain tube fittings into the pre-drilled holes on the underside of the canister by pushing them in place from under the canister. Drain Fitting should click into place.

Place the other end of the drain tube through the plastic/rubber access port or through the pre-drilled holes in the floor or the front wall of the truck bed. If routing through the front wall, ensure that the drain tubes are inserted and directed down so water flows out of the truck.

To remove the drain tubes reach under the canister, grab the drain tube fitting and turn it while applying light downward pressure. When the retaining tabs align with notches in the bottom of the canister the Drain Tube and Fitting will drop out.

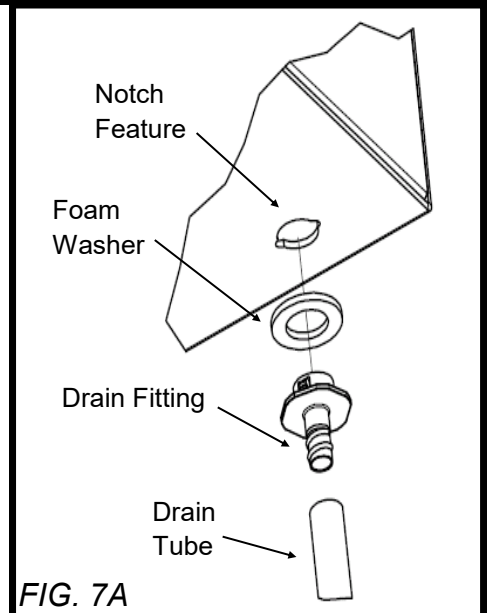

STEP 8: ATTACHING TOP COVER AND VELCRO STRAP

HARDWARE



BLACK TOP COVER SCREW x 4



4" VELCRO STRIP

Place the Top Cover on the canister and install with the four black Top Cover screws through the top cover endcaps and into the panel nuts on the canister flanges.

Retract the cover to the fully open position.

Attach the 4" Velcro strip onto the Velcro strip already attached to the pull strap.

Pull the pull strap over to the driver's side rail and remove the tape from the 4" Velcro strip.

Then apply the Velcro strip onto the underside of the rail at your desired position. This will hold the pull strap off of the floor and out of the way when cargo is being stored in the truck bed.

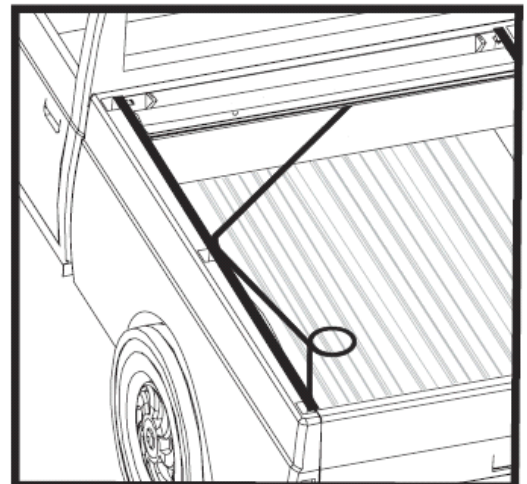

OPERATING INSTRUCTIONS

1. To open the cover, turn the actuator knob clockwise 90° until it clicks in the open position. This retracts the latches into the handle and the cover is free to roll open into the canister. A tug on the pull strap will release the latch and allow the cover to lock into the rails.
2. To latch the cover in one of the mid-range positions, pull it back just beyond the position desired and allow the cover to retract until it latches into place. Latching positions are located every 12 inches along the rails. The clicking sound is the spring-loaded latches mounted inside the handle. The latches are designed to bypass the latching positions as the cover is being closed and to stop the cover as it is being retracted.
3. To close the cover, pull on the strap to draw it back toward the tailgate. When it is within easy reach, grasp the handle by the hand grip and pull the cover to the latching position against the tailgate.

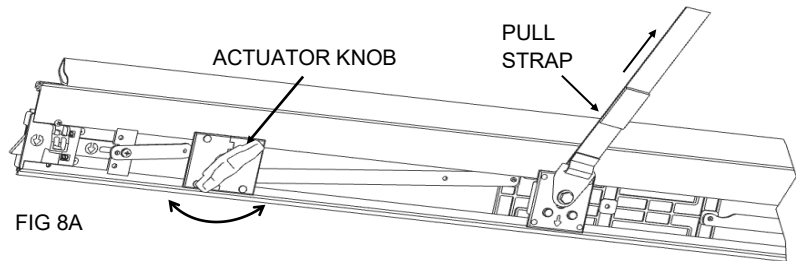

MAINTENANCE

To help keep your Tonneau Cover looking its best, we recommend washing it the same as caring for your truck finish. However, you should not wax your cover. Using a citrus-based vinyl cleaner and UV Protectant will keep your cover looking like new.

To assure quiet, smooth operation, periodically apply a generous amount of UV Protectant to a rag and wipe out the inside of the rails, the underside of the sweep seals, and the top of the wear strips. Repeat as needed until these components are cleaned of debris and well lubricated.

Ensure proper placement of the sweep seal as shown in step 6. Re-apply protectant/lubricant if the cover begins squeaking or sticking during use. (FIG. 6A)

Alcohol, petroleum or silicon-based cleaners such as should be avoided and ARE NOT recommended for our covers.

It is important to open and close the cover regularly. The spring that operates the cover is self-lubricating and regular use assures that it stays in proper working condition.

Periodically remove the Top Cover and clean out the inside of the canister.

Drain tubes may become clogged overtime and should be removed and cleaned. To remove the Drain Tubes reach under the canister, grab the Drain Tube Fitting and turn it while applying light downward pressure. When the retaining tabs align with notches in the bottom of the canister the Drain Tube and Fitting will drop out.

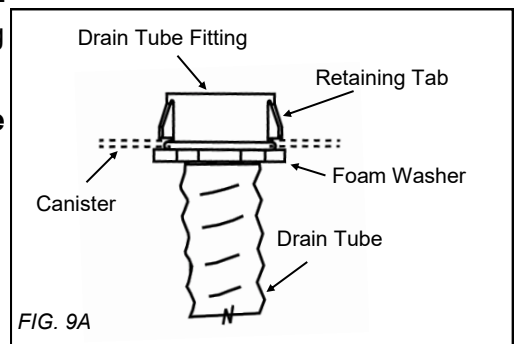
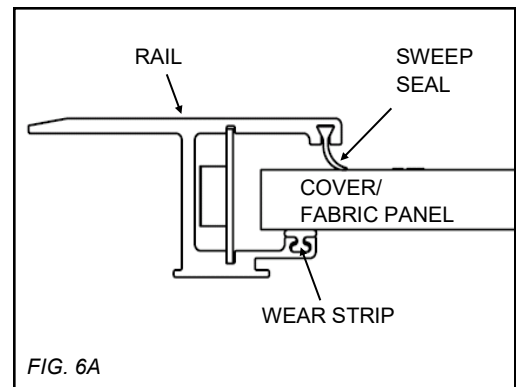

OPERATING INSTRUCTIONS

1. To open the cover, open your tailgate and squeeze (pinch) together the Handle Tabs in the center on the underside of the cover. This retracts the latches and the cover is free to roll open into the canister.
2. To close the cover, pull on the strap to draw it back toward the tailgate. When it is within easy reach, grasp the handle by the hand grip and pull the cover to the latching position against the tailgate.

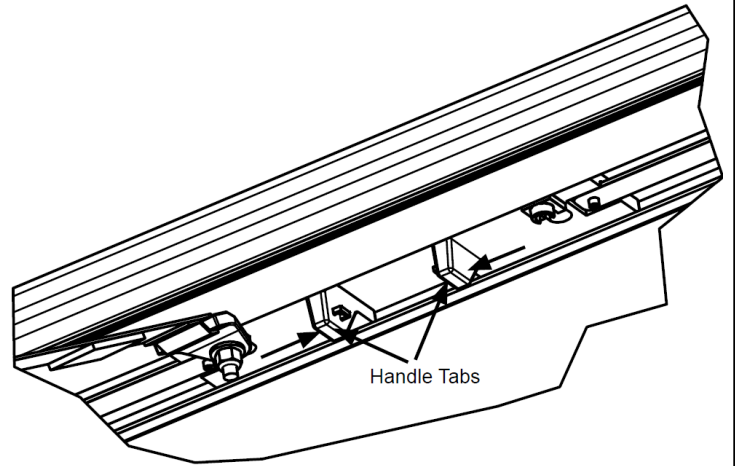

HELPFUL MAINTENANCE HINTS

To help keep your Roll It Up tonneau cover looking its best, we recommend washing it the same as caring for your truck finish. However, you should not wax your cover. Using a citrus-based vinyl cleaner and UV Protectant will keep your cover looking like new.

To assure quiet, smooth operation, periodically apply a generous amount of UV Protectant to a rag and wipe out the inside of the rails, the underside of the sweep seals, and the top of the wear strips. Repeat as needed until these components are cleaned of debris and well lubricated.

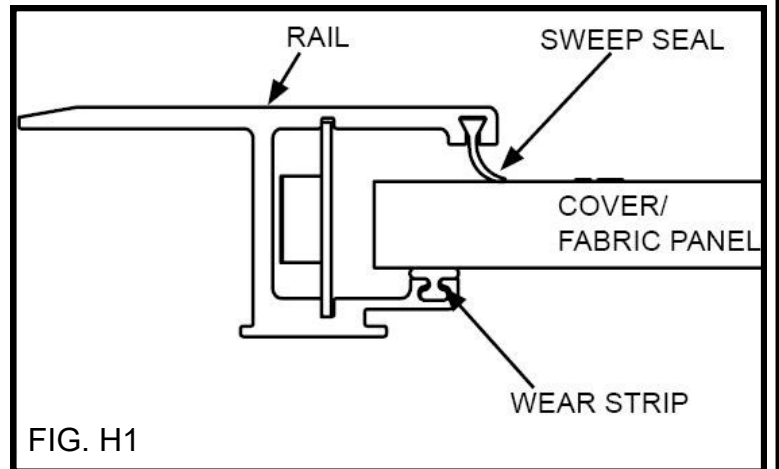

FIG. H1

Ensure proper placement of the sweep seal. Re-apply protectant/lubricant if the cover begins squeaking or sticking during use. (FIG. H1)

Alcohol, petroleum or silicon-based cleaners such as should be avoided and ARE NOT recommended for our covers.

It is important to open and close the cover regularly. The spring that operates the cover is self-lubricating and regular use assures that it stays in proper working condition.

Periodically remove the Top Cover and clean out the inside of the canister.

Drain tubes may become clogged overtime and should be removed and cleaned. To remove the Drain Tubes reach under the canister, grab the Drain Tube Fitting and turn it while applying light downward pressure. When the retaining tabs align with notches in the bottom of the canister

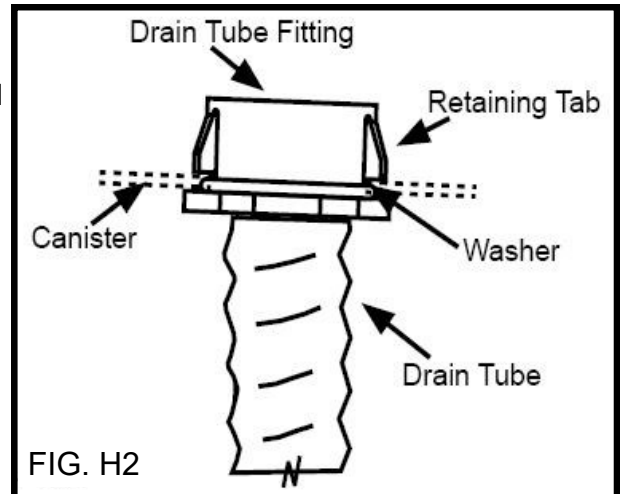

FIG. H2

WARRANTY INFO

Terms of Warranty

The structure of your cover is warranted to be structurally free from defects in material and workmanship for 2 years from the retail date of purchase. The hinges, seals, and hardware are warranted to be free from defects in material and workmanship for 2 years from the retail date of purchase. This warranty applies only to the original purchaser and is nontransferable. Your original sales receipt will serve as proof of purchase for this warranty. Before credit can be issued on a warranty claim, proof of defect may be required. This can be determined at the time of the claim.

Exclusions of Warranty

Not covered under this warranty is failure due to neglect, improper installation including any modifications to installation hardware, alterations, addition of equipment, abuse, accident, weather related damage, exposure to chemicals that are labeled "safe for rubber" and normal wear from lack of maintenance. Caution Always read the ingredients of any product you are using to clean your cover. Make sure that you only use products that are safe for use with rubber. Many chemicals contain material that will permanently discolor or damage your cover hinges and seals. This is not considered a manufacturer defect.

Repair and Replacement

In the event that your cover is found to be defective under the terms of this warranty, it is at our discretion to repair or replace the defective part. All repairs must be made under our direction and we are not responsible for any transportation costs associated with warranted claim.

Maintenance & Care

The surface of your cover require only periodic cleaning with mild car wash soap. Avoid all use of abrasive type cleaners as they may dull the finish. Some chemicals and fluids such as insect repellents, oils, solvents, and lubricants could potentially damage the seals and void the warranty.

By purchasing any item sold by Roll It UP, the buyer expressly warrants that he/she is in compliance with all applicable, State, and Local laws and regulations regarding the purchase, ownership, and use of the item. It shall be the buyers responsibility to comply with all Federal, State and Local laws governing the sales of any items listed, illustrated or sold. The buyer expressly agrees to indemnify and hold harmless Roll it up for all claims resulting directly or indirectly from the purchase, ownership, or use of the items.