

# ROLLITUP®

## DODGE RAM INSTALLATION INSTRUCTIONS

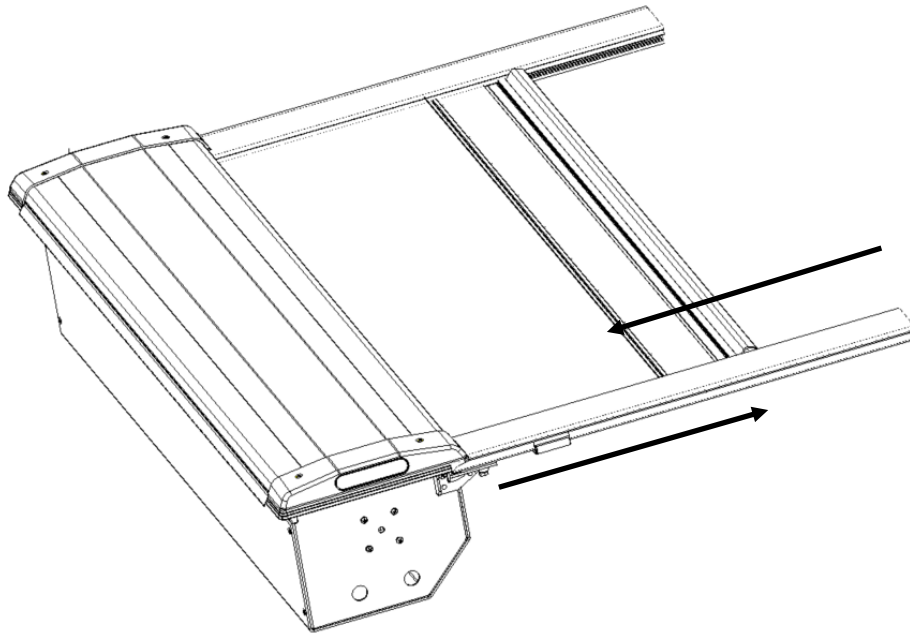

Questions? Comments?

Please send LEER Tonneau  
Covers a direct message  
through Amazon

We are always here to help!

R2WD1-2306

### TABLE OF CONTENTS

Tools Required for Assembly .....	2
Before You Start .....	2
Drain Hole Locations .....	2
1. Remove Packaging Plywood & Hardware Packaging .....	2
2. Positioning Canister .....	3
3. Installing Rails .....	3
4. Installing Clamps .....	4
5. Attaching Pull Strap.....	4
6. Installing Kickstands .....	5
7. Lubricating & Placing Sweep Seals .....	5
8. Installing Drain Tubes .....	6
9. Installing Top Cover & Velcro .....	6
Operating Instructions .....	7
Helpful Maintenance Hints .....	7
Warranty Statement .....	8

## TOOLS REQUIRED FOR ASSEMBLY:

7/16" Wrench or Socket  
#2 Phillips Screwdriver

Tape Measure  
Side Cut or Needle Nose Pliers

Utility Knife

*Note: There should be no drilling into the truck body needed on most standard or full-size trucks.*

## BEFORE YOU START:

Read the instructions carefully before you start. These instructions are written for one-person installation. We have briefly noted where having an extra person's assistance can make installation easier.

If you have any questions about installation please send LEER Tonneau Covers a direct message through Amazon.

## DRAIN HOLE LOCATIONS:

The Roll It Up is designed to carry rainwater from the cover into the canister and then out through the drains. Most truck models have standard OE drain holes or plastic/rubber access ports in the front of the truck bed. Check to make sure your truck has the OE drain holes so that drilling into the sheet metal is not required. If drilling is necessary, be sure to check the underside of the truck bed for the best location. The holes should be located near the side and as far forward as possible. Use a drill bit suitable for sheet metal (such as a taper drill or step drill). Drill drain tube clearance holes at 3/4" (19mm). This will need to be done before installing the cover.

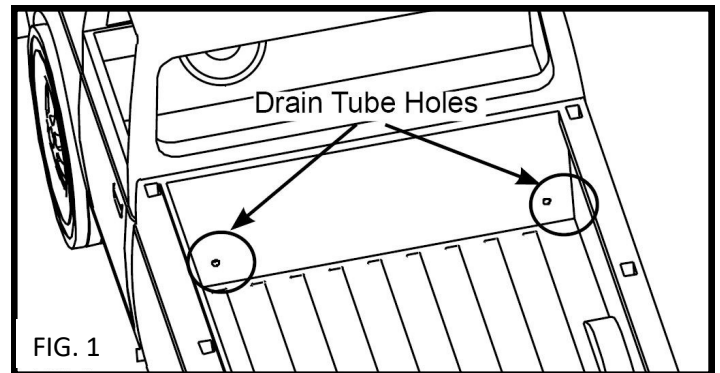

## STEP 1: REMOVE PACKAGING PLYWOOD & HARDWARE

Unpack the Top Cover, Canister, Rails, Clamp Pack, and Hardware Pack from the canister box. Perform a quick inventory of the packaging contents to insure all parts are there.

**CAUTION!**

**TO AVOID SCRATCHING ANY PARTS PLEASE CUT THE TAPE FROM THE FOAM PACKAGING WITH SCISSORS AND UNWRAP THEM ON A SOLID SURFACE E.G. THE DECONSTRUCTED BOX YOU JUST EMPTIED**

**CAUTION!**

## PACKAGING CONTENTS

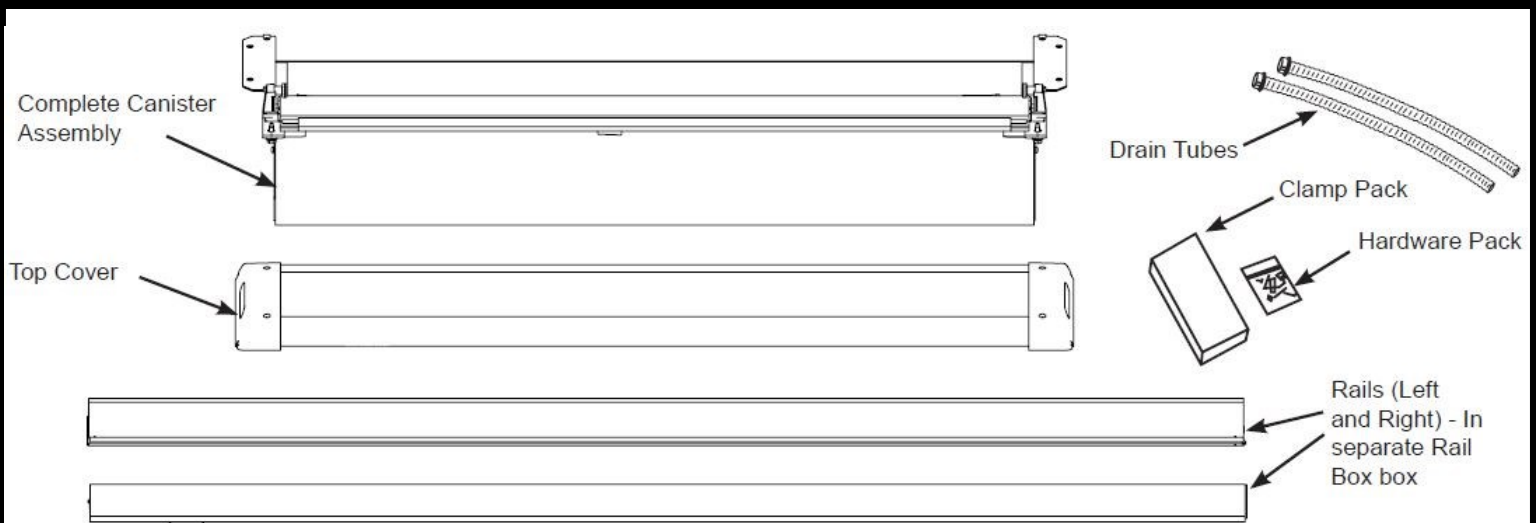

## STEP 2: POSITIONING THE CANISTER

Use the Pull-strap and one canister flange to lift and steady the unit. Wrap the Pull-strap around the canister a couple of times and double it up in your hand.



Place the Canister in the truck bed just behind the cab and center it from side to side. Ensuring that the canister is centered in the bed will help assemble the rails to the canister in the next step.

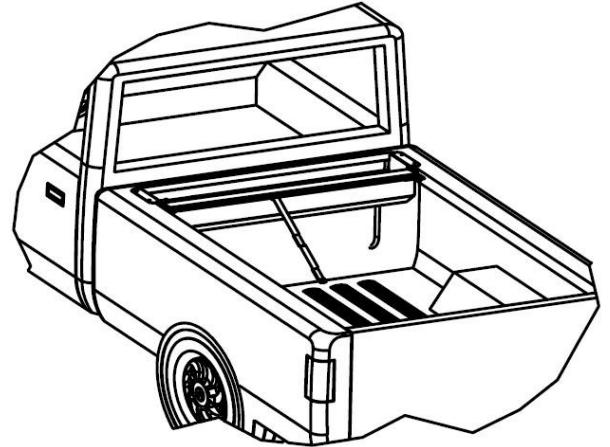

## STEP 3: INSTALLING RAILS

### HARDWARE USED:

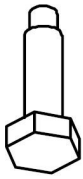

1/4-20 x 1"  
RAILBOLT x2



1/4" LOCK WASHER x2



1/4" FLAT WASHER x2

Remove the protective paper from the foam on the underside of the Rail Flanges. This is for packaging purposes only. The rails shipped with plastic shims pre-installed to the Rail Brackets for proper spacing. Ensure those shims are in place.

Next identify the left and right side rails. The plastic rail endcap should be towards the tailgate while the rail flange, foam, shims and brackets towards the outside of the truck bed. Install the rails by first guiding the Handle Assembly into the open channel of the rail and then sliding the rail against the blanket guide on the canister. Attach the rail to the canister using the rail bolt, lock washer and flat washer through the blanket guide and into the bottom of the rail.

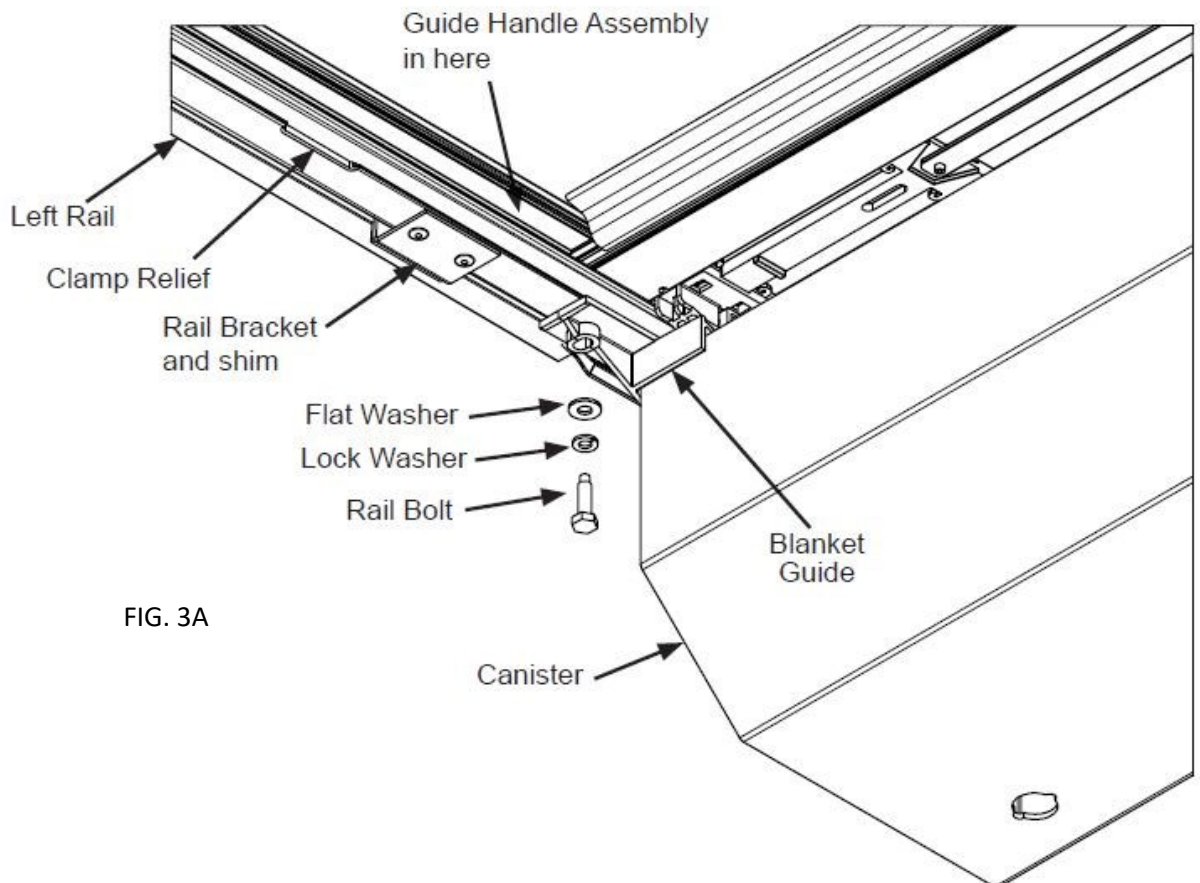

FIG. 3A

# STEP 4: INSTALLING THE CLAMPS

Secure the rails to the truck bed by installing two clamp assemblies per rail. Slide the Clamp Grip onto the Rail at the Clamp Relief and then slide it towards the Rail Bracket and Shim (Fig 4E and 4F). Then assemble the rest of the clamp parts as shown below (Fig 4C & 4D). Slide the Pivot Arm in from the canister side to avoid any interferences. Be sure to use the long clamp grip at the canister end (FIG 4D) and the shorter clamp grip at the tailgate end (FIG 4C).

Before tightening the rail clamps, set the Rail End Caps about 1/16" from the tailgate. This space will allow for overstroke when closing the tailgate. Once everything is square, tighten the Rail clamps completely but **do NOT tighten over 120 inch-pounds!**

Finally, check for proper spacing by measuring between the rails at the canister and the tailgate end of the rails (Fig 4A). The measurement should be equal to less than those in Fig 4B. The Rail Brackets and Shims have been pre-installed to achieve the proper Between the Rail dimensions (BR) when placed on an average factory truck bed. However, not all truck beds are average dimensionally and some have optional plastic caps or over the rail spray-in bedliners.

PART NUMBER	BETWEEN THE RAILS (BR)
SW2077	58 3/16

Part number is on the serial number label in the upper-left corner of the canister (looking from tailgate).

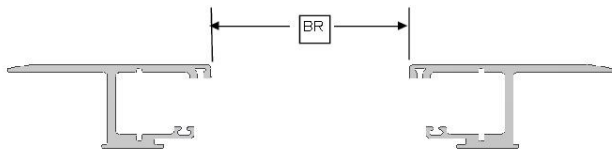

FIG. 4A

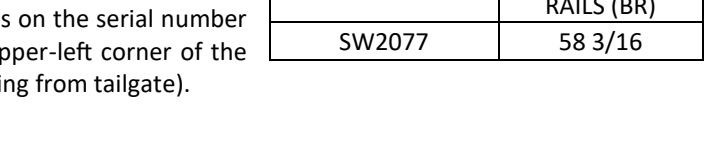

FIG. 4B

Another way to ensure proper fit is to check the side to side play of the handle assembly at the canister and at the tailgate end of the rails. There should be, at minimum, enough play to allow the cover to move freely with no drag and at a maximum 1/8" per side. More than 1/8" per side may result in the cover opening unintentionally and in severe cases it may fall between the rail tracks and damage the cover. **There are shims on the brackets that can be removed if the unit is too tight and shims in the hardware pack that can be added if too loose.**

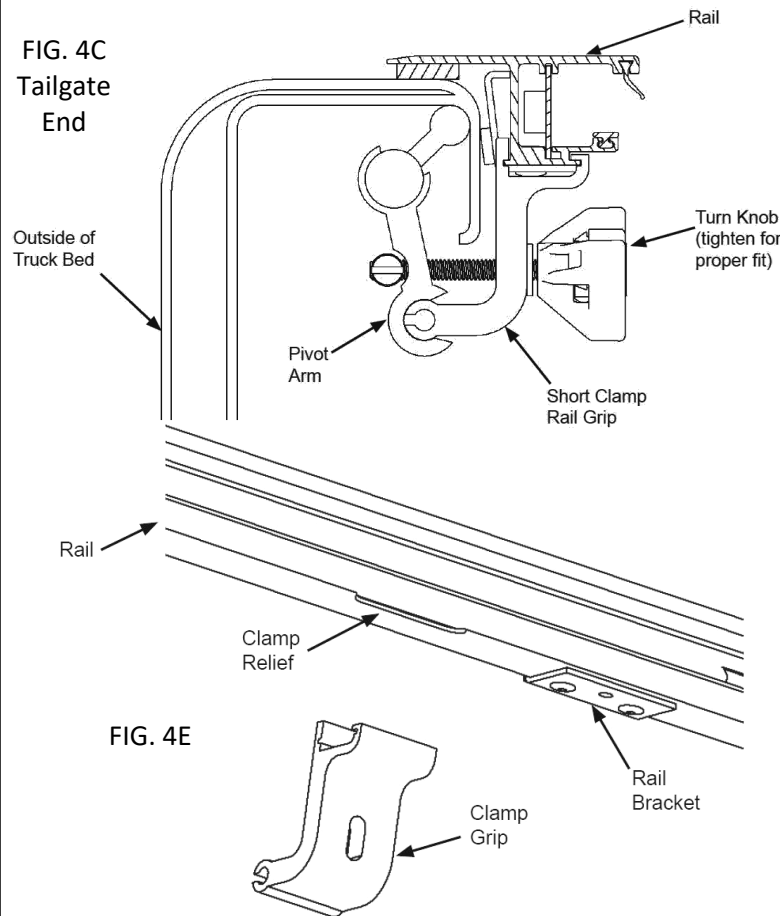

FIG. 4C  
Tailgate  
End

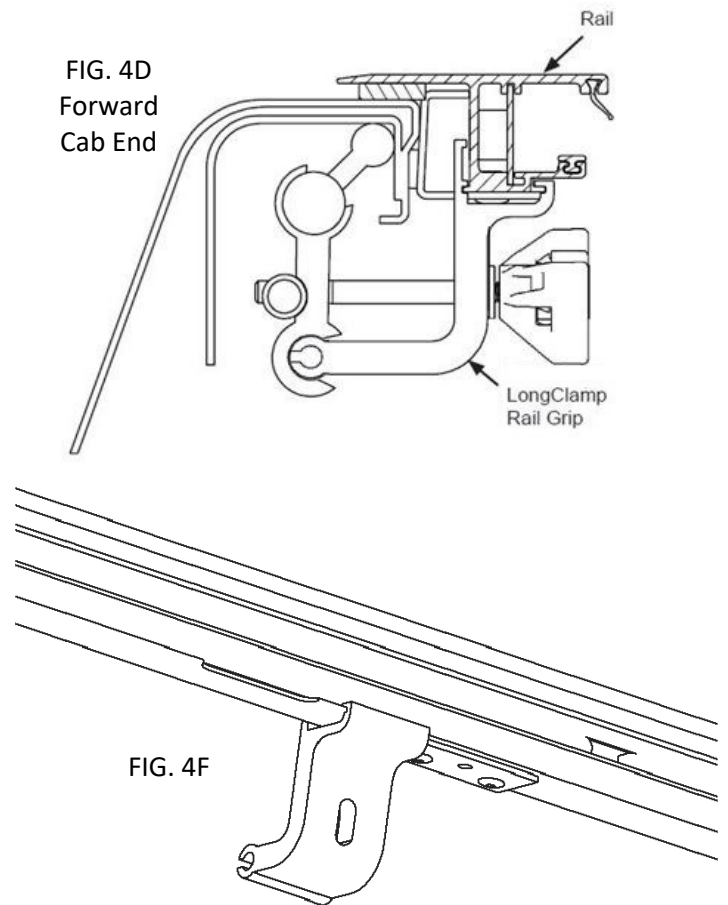

FIG. 4D  
Forward  
Cab End

# STEP 5: ATTACH THE PULL-STRAP

Attach your pull-strap to either of the clamps (left or right side) at the tailgate end of the rails by looping it through the assembly and pressing the two Velcro strips together. This will ensure the pull-strap will always be within easy reach when trying to close the cover.

## STEP 6: INSTALLING THE KICKSTANDS

Install the kickstands at the tailgate ends of the rails (FIG. 6A). Loosely fasten the kickstand assembly to the clamp grip, on the side of the grip where the pivot foot will land on the flattest section of the bed wall. Rotate the assembly so that the kickstand will push as squarely as possible against the bed wall (FIG. 6B), then tighten the wing nut. If the assembly is not positioned squarely against the bed wall, the assembly will rotate out of position, or the foot or knob can dislodge when the rail is flexed or loaded (FIG. 6C).

Run the adjusting bolt inward toward the bed wall, putting some pressure on the foot. Continue running the bolt inward using the knob until the rail is visually level. The adjusting bolt can be removed and the base flipped 180 degrees to adjust for varying clearance with the bed wall (FIG. 6D). Verify the BTR dimension after the rails are leveled (STEP 4, FIG 4A & 4B).

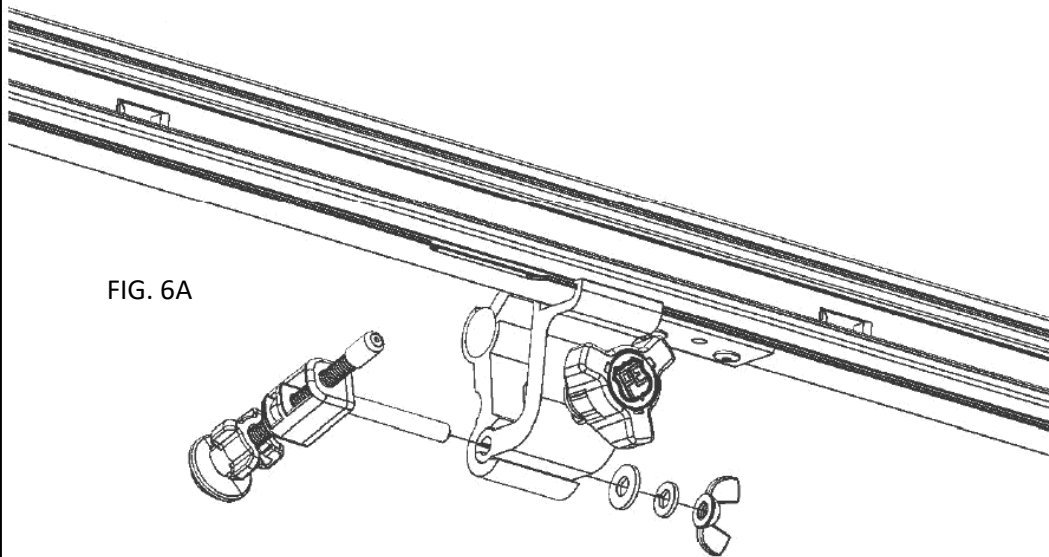

FIG. 6A

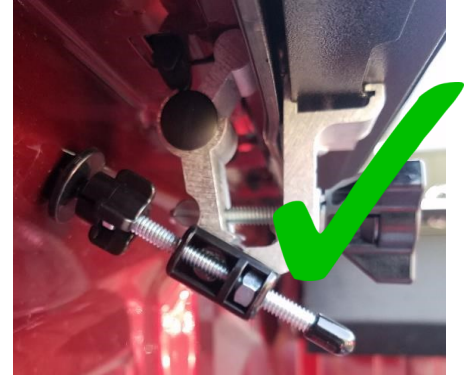
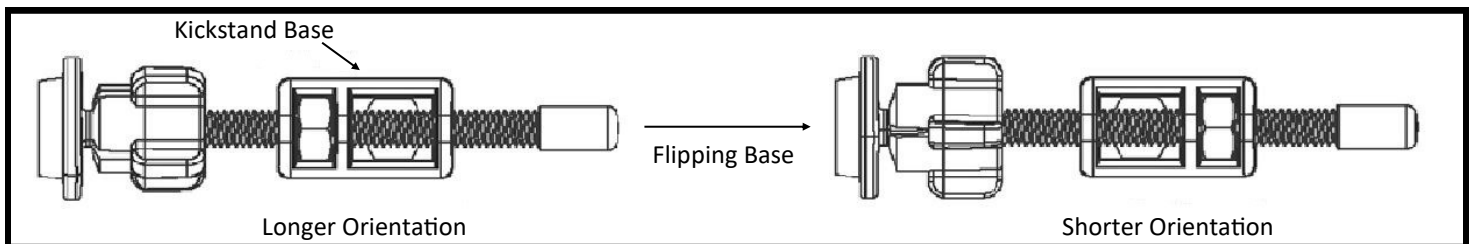

FIG. 6B



FIG. 6C

FIG. 6D



## STEP 7: LUBRICATING & PLACING THE SWEEP SEALS

Locate the sweep seals (rubber weather strips) on the rails. Use the provided UV protectant to wipe the underside of the sweep seal and the top of the wear strip on each rail. The UV protectant can be found adhered to the underside of the top cover lid or in the hardware pack.

Extend the cover to the tailgate. Use an Allen Wrench if needed to carefully draw out the sweep seal (seal should be angled outwards toward the cover—not rolling in toward the bed rail). (Fig. 7A)

Proper care and placement of the sweep seal will ensure smooth operation of the cover. Alcohol, petroleum or silicone based cleaners should be avoided and ARE NOT recommended for our covers.

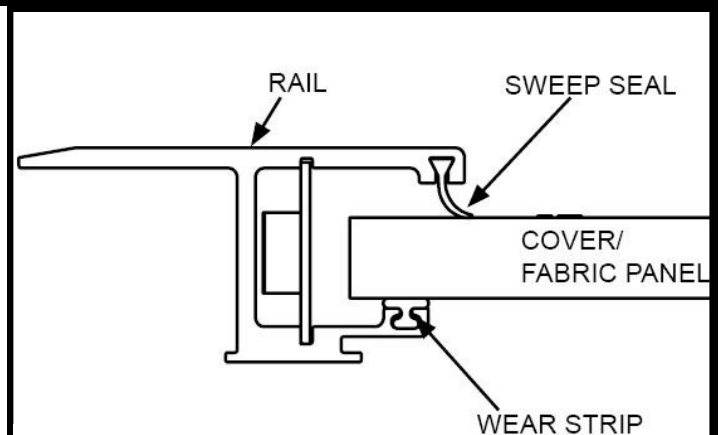

FIG. 7A

## STEP 8: INSTALLING THE DRAIN TUBES

First, ensure that the Foam Washer is in place on the Drain Fitting as this washer will help prevent water leakage. Next, test fit the drain tube to determine the length you want to trim it. Always caution on the long side. Trim the end that will be inserted through the truck bed using the wire cutters or a utility knife.

With the cover opened, insert the drain tube fittings into the pre-drilled holes on the underside of the canister by pushing them in place from under the canister. Drain Fitting should click into place.

Place the other end of the drain tube through the plastic/rubber access port or through the pre-drilled holes in the floor or the front wall of the truck bed. If routing through the front wall, ensure that the drain tubes are inserted and directed down so the water flows out of the truck bed.

To remove the drain tubes reach under the canister, grab the drain tube fitting and turn it while applying light downward pressure. When the retaining tabs align with the notches in the bottom of the canister the Drain Tube and Fitting will drop out.

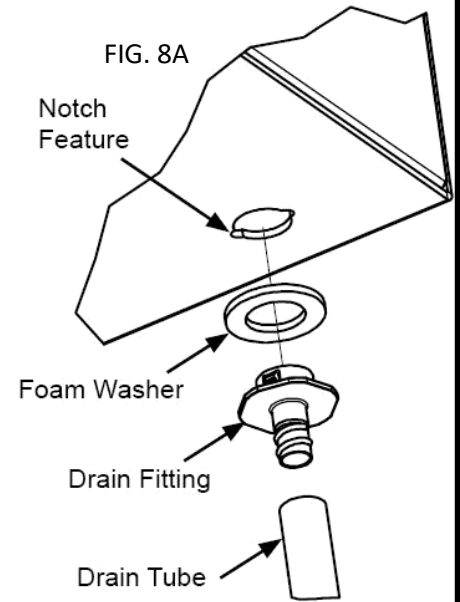

## STEP 9: ATTACHING TOP COVER & VELCRO TO PULL-STRAP

### HARDWARE USED:



4" Velcro Strip



Black Top Cover  
Screw x4

Place the Top Cover on the canister and install with the four Black Top Cover Screws through the top cover endcaps and into the panel nuts on the canister flanges.

Retract the cover to the fully open position.

Attach the 4" Velcro Strip onto the Velcro already attached to the pull-strap.

Pull the pull-strap over to the driver or passenger side rail and remove the tape from the 4" Velcro Strip.

Then apply the Velcro Strip onto the underside of the rail at your desired position.

This will hold the pull-strap off of the floor and out of the way when cargo is being stored in the truck bed.

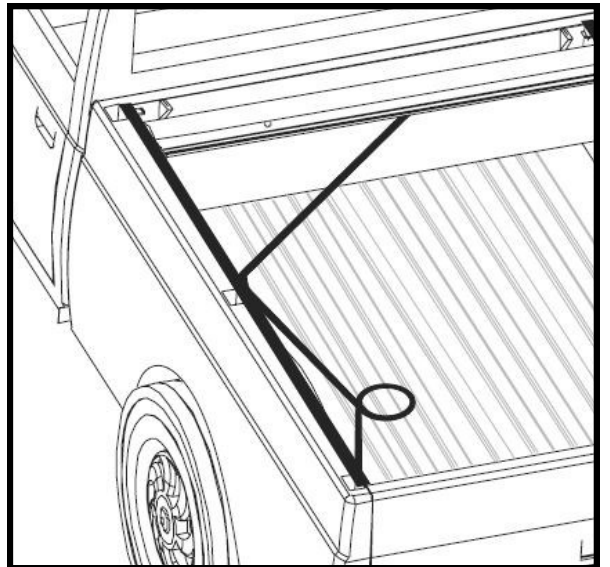

# OPERATING INSTRUCTIONS

1. To open the cover, open your tailgate and squeeze (pinch) together the Handle Tabs in the center on the underside of the cover. This retracts the latches and the cover is free to roll open into the canister.
2. To close the cover, pull on the strap to draw it back toward the tailgate. When it is within easy reach, grasp the handle by the hand grip and pull the cover to the latching position against the tailgate.

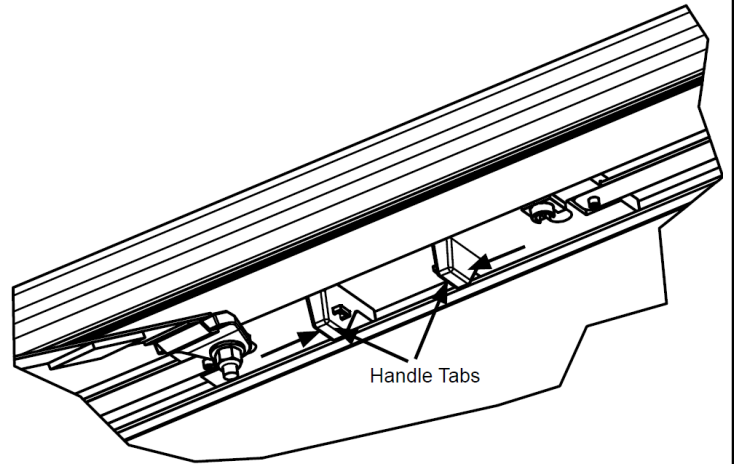

# HELPFUL MAINTENANCE HINTS

To help keep your Roll It Up tonneau cover looking its best, we recommend washing it the same as caring for your truck finish. However, you should not wax your cover. Using a citrus-based vinyl cleaner and UV Protectant will keep your cover looking like new.

To assure quiet, smooth operation, periodically apply a generous amount of UV Protectant to a rag and wipe out the inside of the rails, the underside of the sweep seals, and the top of the wear strips. Repeat as needed until these components are cleaned of debris and well lubricated.

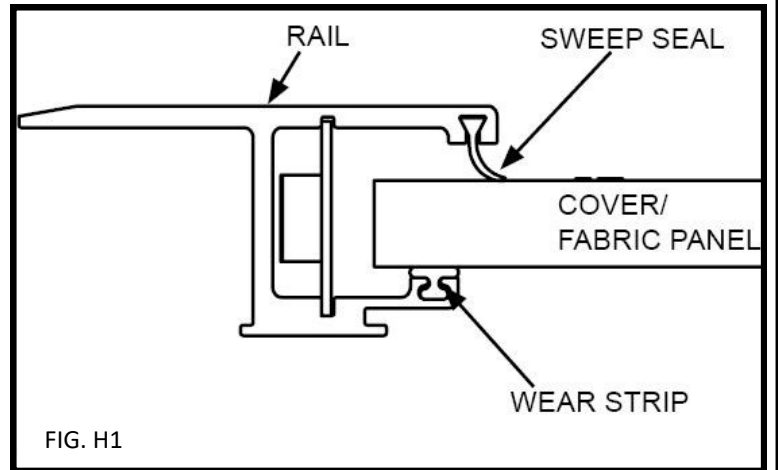

FIG. H1

Ensure proper placement of the sweep seal. Re-apply protectant/lubricant if the cover begins squeaking or sticking during use. (FIG. H1)

**Alcohol, petroleum or silicon-based cleaners such as should be avoided and ARE NOT recommended for our covers.**

It is important to open and close the cover regularly. The spring that operates the cover is self-lubricating and regular use assures that it stays in proper working condition.

Periodically remove the Top Cover and clean out the inside of the canister.

Drain tubes may become clogged overtime and should be removed and cleaned. To remove the Drain Tubes reach under the canister, grab the Drain Tube Fitting and turn it while applying light downward pressure. When the retaining tabs align with notches in the bottom of the canister the Drain Tube and Fitting will drop out.

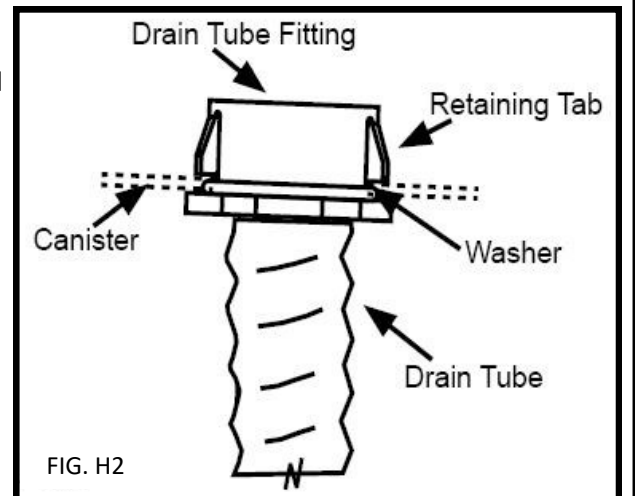

FIG. H2

# WARRANTY INFO

## Terms of Warranty

The structure of your cover is warranted to be structurally free from defects in material and workmanship for 2 years from the retail date of purchase. The hinges, seals, and hardware are warranted to be free from defects in material and workmanship for 2 years from the retail date of purchase. This warranty applies only to the original purchaser and is nontransferable. Your original sales receipt will serve as proof of purchase for this warranty. Before credit can be issued on a warranty claim, proof of defect may be required. This can be determined at the time of the claim.

## Exclusions of Warranty

Not covered under this warranty is failure due to neglect, improper installation including any modifications to installation hardware, alterations, addition of equipment, abuse, accident, weather related damage, exposure to chemicals that are labeled "safe for rubber" and normal wear from lack of maintenance. Caution Always read the ingredients of any product you are using to clean your cover. Make sure that you only use products that are safe for use with rubber. Many chemicals contain material that will permanently discolor or damage your cover hinges and seals. This is not considered a manufacturer defect.

## Repair and Replacement

In the event that your cover is found to be defective under the terms of this warranty, it is at our discretion to repair or replace the defective part. All repairs must be made under our direction and we are not responsible for any transportation costs associated with warranted claim.

## Maintenance & Care

The surface of your cover require only periodic cleaning with mild car wash soap. Avoid all use of abrasive type cleaners as they may dull the finish. Some chemicals and fluids such as insect repellents, oils, solvents, and lubricants could potentially damage the seals and void the warranty.

By purchasing any item sold by Roll It UP, the buyer expressly warrants that he/she is in compliance with all applicable, State, and Local laws and regulations regarding the purchase, ownership, and use of the item. It shall be the buyers responsibility to comply with all Federal, State and Local laws governing the sales of any items listed, illustrated or sold. The buyer expressly agrees to indemnify and hold harmless Roll it up for all claims resulting directly or indirectly from the purchase, ownership, or use of the items.

For any assistance regarding technical support or warranty claims, please send LEER Tonneau Covers a direct message through Amazon