

JACKRABBIT SERIES

RETRACTABLE TRUCK BED COVERS

NISSAN FRONTIER INSTALLATION INSTRUCTIONS



(800) 338-3697 toll free
(360) 736-9992 fax

www.pace-edwards.com

Pace Edwards Company
2400 Commercial Blvd
Centralia WA 98531

JRN4-2302

TABLE OF CONTENTS

Tools Required for Assembly	1
Before You Start	1
Drain Hole Locations	1
1. Remove Packaging Plywood & Hardware Packaging	1
2. Positioning Canister	2
3. Installing Rails	2
4. Repositioning Canister & Rails.....	4
5. Installing Clamps	5
6. Installing Kickstands	6
7. Lubricating & Placing Sweep Seals	6
8. Installing Drain Tubes	7
9. Installing Top Cover & Velcro	7
Operating Instructions	8
Helpful Maintenance Hints	8
Warranty Statement	9
Copy of Warranty	10

TOOLS REQUIRED FOR ASSEMBLY:

3/8" Wrench or Socket
#2 Phillips Screwdriver

Tape Measure
Side Cut Pliers Or Needle Nose Pliers

Masking Tape
Utility Knife or Scissors

Note: There should be no drilling into the truck body needed on most standard or full-size trucks.

BEFORE YOU START:

Read the instructions carefully before you start. These instructions are written for one-person installation. We have briefly noted where having an extra person's assistance can make installation easier.

If you have questions regarding the installation of your new retractable tonneau cover, please call our Technical Support Line at (800) 338-3697 Ext #1.

DRAIN HOLE LOCATIONS:

The JackRabbit is designed to carry rainwater from the cover into the canister and then out through the drains. Most truck models have standard OE drain holes or plastic/rubber access ports in the front of the truck bed. Check to make sure your truck has the OE drain holes so that drilling into the sheet metal is not required. If drilling is necessary, be sure to check the underside of the truck bed for the best location. The holes should be located near the side and as far forward as possible. Use a drill bit suitable for sheet metal (such as a taper drill or step drill). Drill drain tube clearance holes at 3/4" (19mm). This will need to be done before installing the cover.

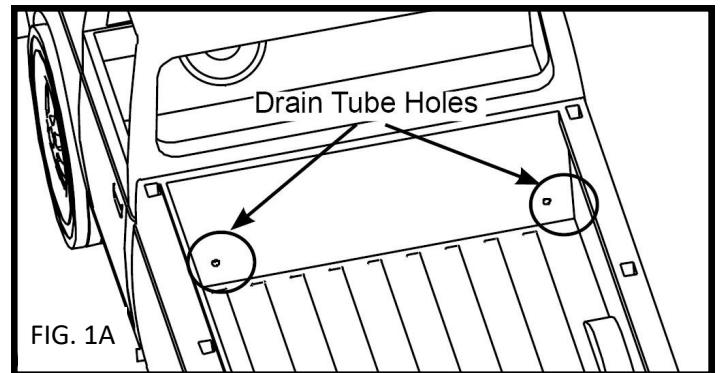

STEP 1: REMOVE PACKAGING AND REVIEW CONTENTS

A complete unit will consist of one canister box (marked box 1 of 2) and one rail box (marked box 2 of 2). Remove the Top Cover, Canister, Clamp pack, Hardware pack, Foam, and Drain Tubes from the Canister box. Remove the rails from the rail box (see caution below). Perform a quick inventory of the packaging contents to ensure all parts are there.



TO AVOID SCRATCHING THE SURFACE OF THE RAILS, DO NOT SLIDE THEM OUT THE END OF THE BOX ALONG THE LENGTH, USE PLIERS TO PULL THE STAPLES, LIFT THE RAIL OUT. DO NOT USE A KNIFE TO CUT THE BOX OPEN.



PACKAGING CONTENTS

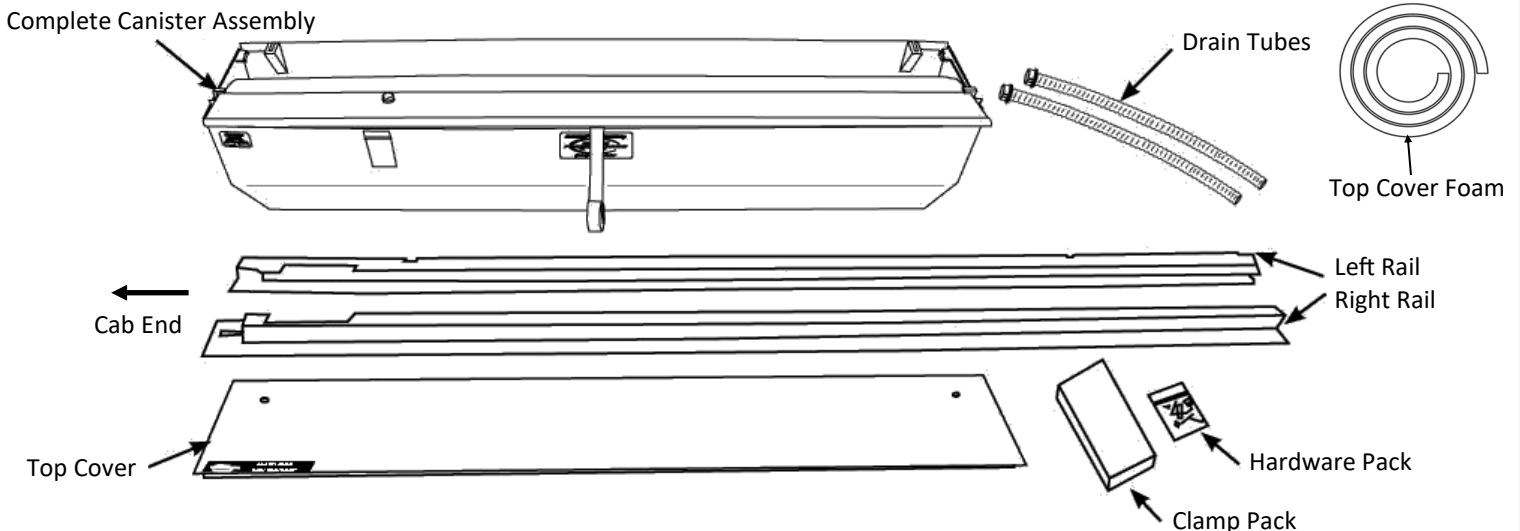

STEP 2: POSITIONING THE CANISTER

If installing the product on your own, place the canister in the truck bed just behind the cab and center it from side to side. To lift the can, wrap the pull strap around the can a couple of times and double it up in your hand (FIG. 2A).

You will need to place the canister on elevating objects, such as the box the canister came in, or 5 gallon buckets. The objects must clear the truck bed by 2-3" (FIG. 2B).

If you have another person to help, you can jump to step 3 and install the rails outside of the truck bed.



FIG. 2A

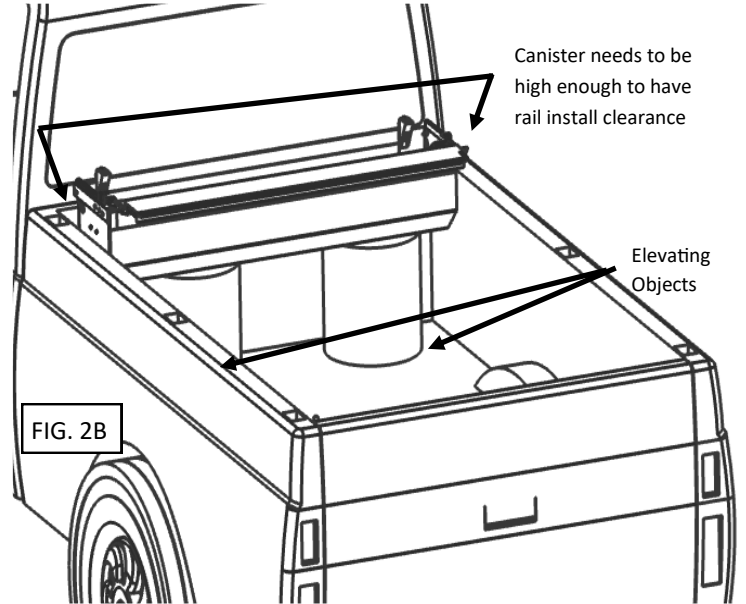

FIG. 2B

STEP 3: INSTALLING THE RAILS

HARDWARE USED:



1/4-20 x 3/4" BOLT x2



1/4" LOCK WASHER x2



1/4" FLAT WASHER x2

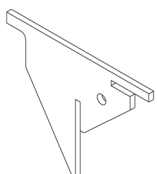

INSTALLATION
TOOL x 1

Identify the left and right side rails, the end with the plastic cap will be facing the tailgate.

REMOVE THE PROTECTIVE PAPER ON UNDERSIDE OF RAILS. THIS IS FOR PACKAGING PURPOSES ONLY!

Slide the slotted cutout on the installation tool onto the front of the canister near the center, but not touching the pull strap. Make sure the hole is facing toward the truck cab and the tool is secured to the front of the canister. Rest the handle on top of the installation tool (FIG. 3A).

CAUTION!

**MAKE SURE THE LATCHES ARE IN!
IF THE LATCHES ARE OUT THE HANDLE WILL CATCH ON THE RAIL AS
YOU ATTEMPT TO SLIDE IT IN. SEE FIG. 3B & 3C**

CAUTION!

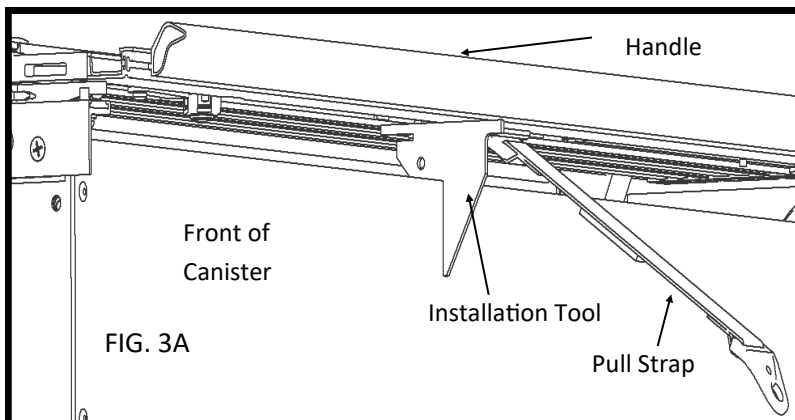

FIG. 3A

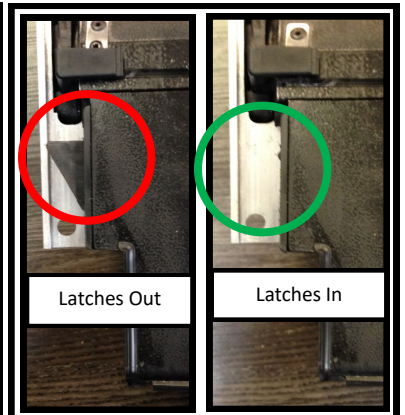
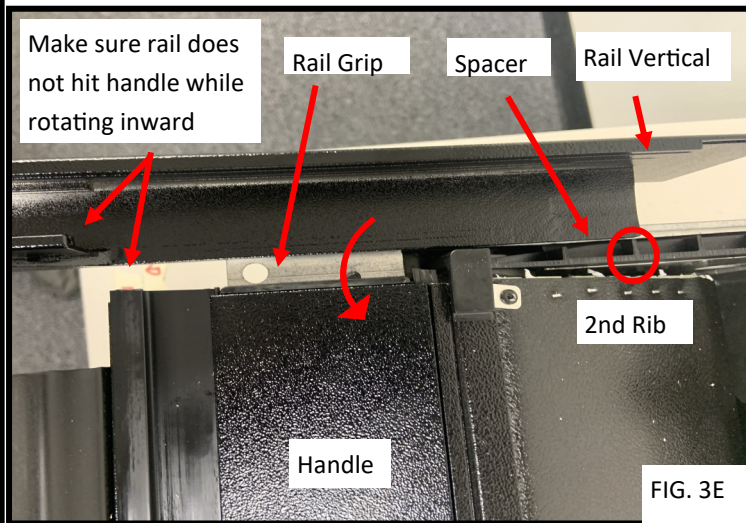
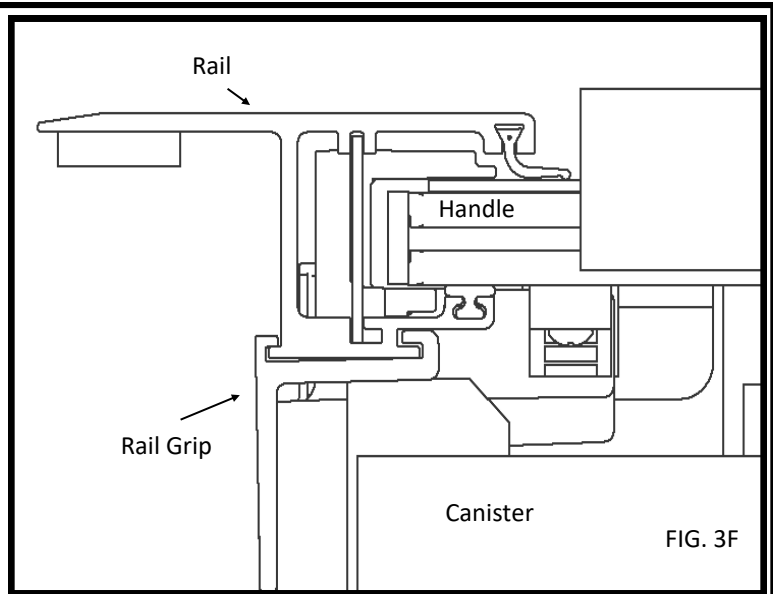
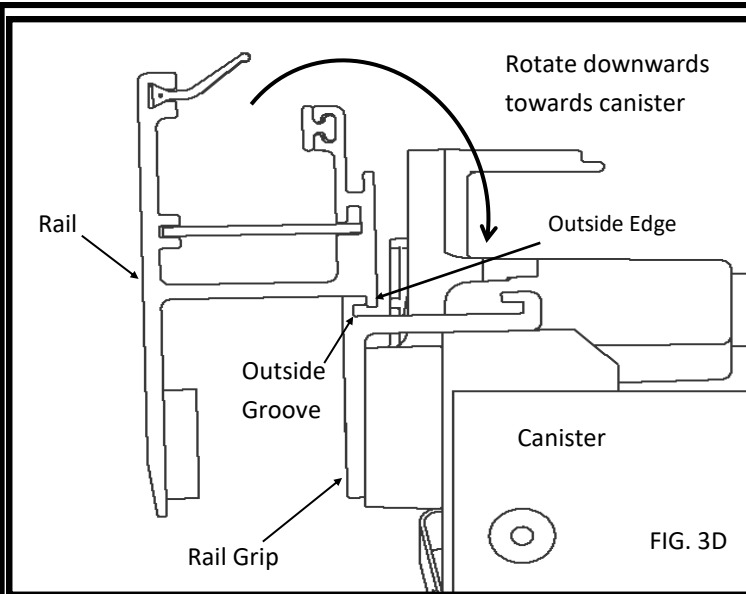

FIG. 3B & C



Using the outside edge of the rail (away from the can), hook the rail onto the rail grip's outside groove (FIG. 3D).

Slide along the rail grip until the rail vertical is parallel to the 2nd rib of the spacer. Rotate the rail towards the canister, while keeping the outside edge of the rail locked in the groove (FIG. 3E).

If the handle is making contact with the rail, confirm the cover is fully retracted into the canister.

Once the rail is level with the grip, push the rail forward whilst maintaining light pressure over the rail (FIG. 3G).

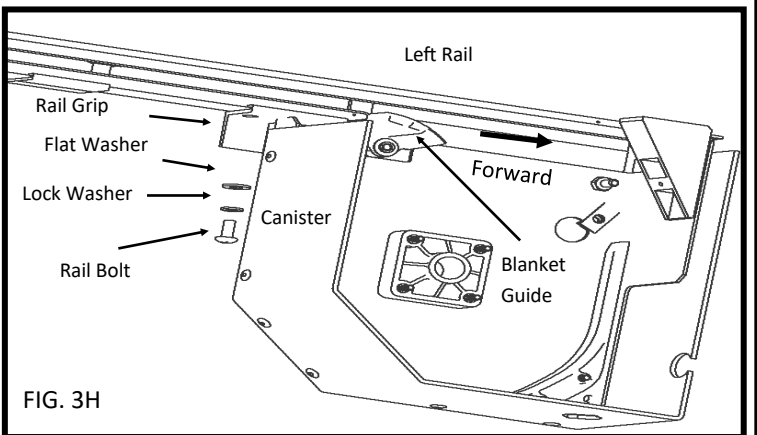
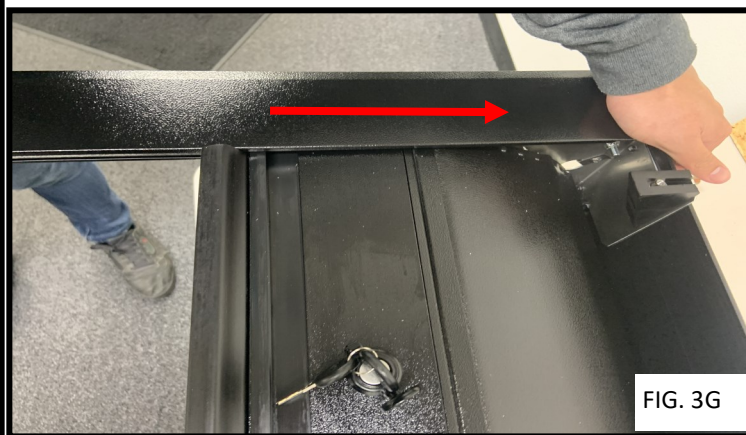

INSTALL TIP!

IF THE RAIL IS GETTING STUCK WHILE PUSHING FORWARD, AND THE RAIL IS LEVEL WITH THE GRIP; THEN GENTLY LIFT UP ON THE HANDLE WITH ONE HAND WHILE PUSHING THE RAIL FORWARD WITH THE OTHER.

INSTALL TIP!

Once the rail vertical reaches the end of the grip, thread the rail bolt with the lock washer and flat washer through the rail grip into the rail. Use a Philips #2 screwdriver to tighten (FIG 3H).

INSTALL TIP!

IF YOU ARE INSTALLING THE RAILS OUTSIDE THE TRUCK BED, USE THE CLAMP BOX TO SUPPORT THE FIRST RAIL TO PREVENT ANY DAMAGE TO THE RAIL. (FIG. 3J)

INSTALL TIP!

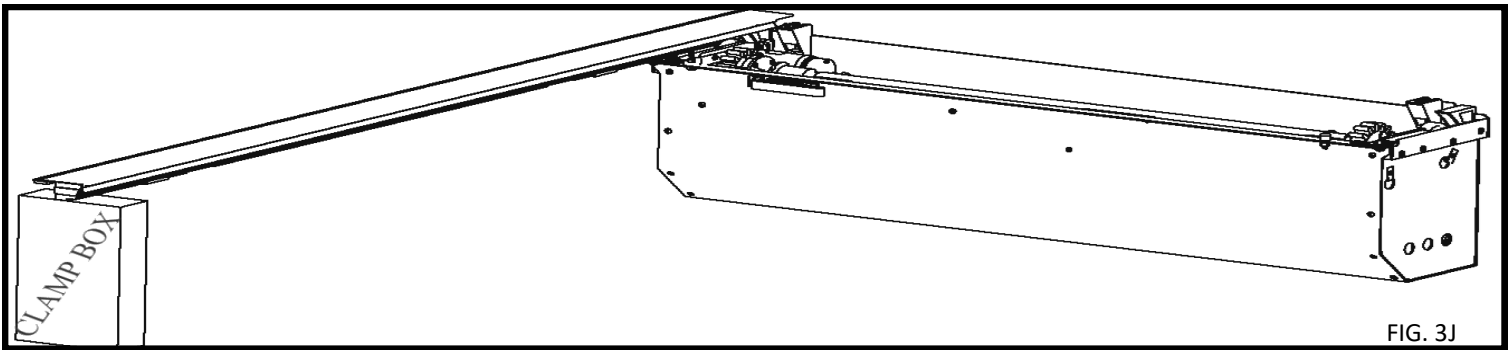

The rails and canisters shown are for REFERENCE, and may not exactly match your cover.

CAUTION!

DO NOT FORGET TO TAKE THE INSTALLATION TOOL OFF THE CANISTER ONCE BOTH RAILS ARE INSTALLED.

CAUTION!

STEP 4: REPOSITIONING THE CANISTER & RAILS

If you installed the rails outside the truck bed, with another person, lift the assembled canister into the truck bed. Center the canister between the bed. Otherwise remove the support(s) from under the canister so that the canister and rails rest firmly on the sides of the truck bed.



With the tailgate closed, position the rails so the endcaps are 1/16" away from the tailgate (FIG. 4A)

STEP 5: INSTALLING THE CLAMPS

Secure the rails to the truck bed by installing two clamp assemblies per rail. Slide the Clamp Grip onto the Rail at the Clamp Relief and then slide it towards the Rail Bracket and Shim (Fig 5C and 5D).

Before installing the rail clamps, set the Rail End Caps about 1/16" from the tailgate. This space will allow for overstroke when closing the tailgate. Once everything is square, insert the Turn Knob through the Clamp Grip and push up the Clamp Back Plate as much as possible while tightening the Turn Knob (FIG. 5E). Make Sure the Clamp is pushed up as far as possible in the Clamp Grip slot (FIG. 5F).



Tighten the Rail Clamps completely but **do NOT** tighten over 120 inch-pounds!



Check for proper spacing by measuring between the rails at the canister and the tailgate end of the rails (Fig 5A). The measurement should be equal to or less than those in Fig 5B. The Rail Brackets and Shims have been pre-installed to achieve the proper Between the Rail dimensions (BR) when placed on an average factory truck bed. However, not all truck beds are average dimensionally and some have optional plastic caps or over the rail spray-in bedliners.



FIG. 5A

Part number is on the serial number label in the upper-left corner of the canister (looking from tailgate).

FIG. 5B

PART NUMBER	BETWEEN THE RAILS (BR)
TR2182	54 13/16
TR2183	54 13/16

Another way to ensure proper fit is to check the side to side play of the handle assembly at the canister and at the tailgate end of the rails. There should be, at minimum, enough play to allow the cover to move freely with no drag and at a maximum 1/8" per side. More than 1/8" per side may result in the cover opening unintentionally and in severe cases it may fall between the rail tracks and damage the cover. **There are shims on the brackets that can be removed if the unit is too tight and shims in the hardware pack that can be added if too loose.**

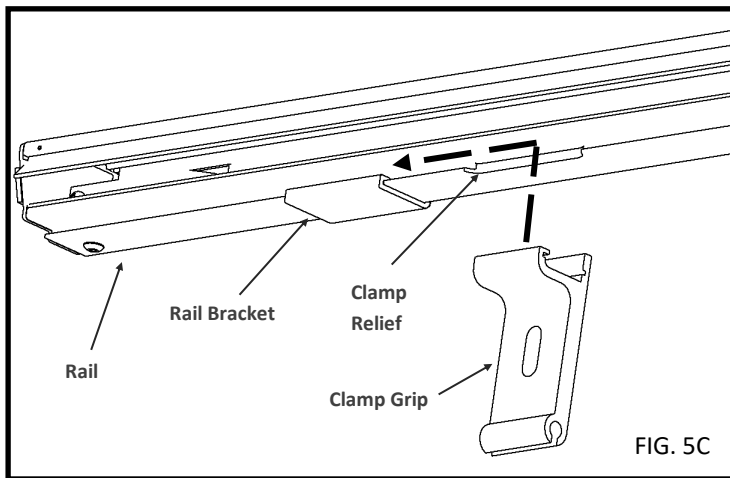

FIG. 5C

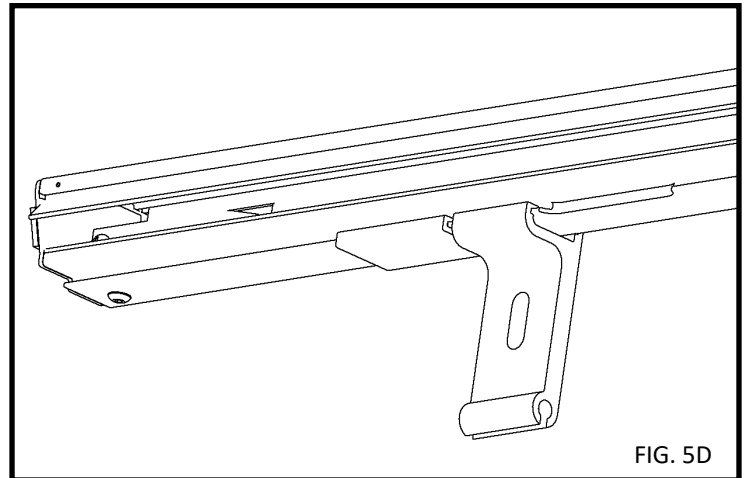

FIG. 5D

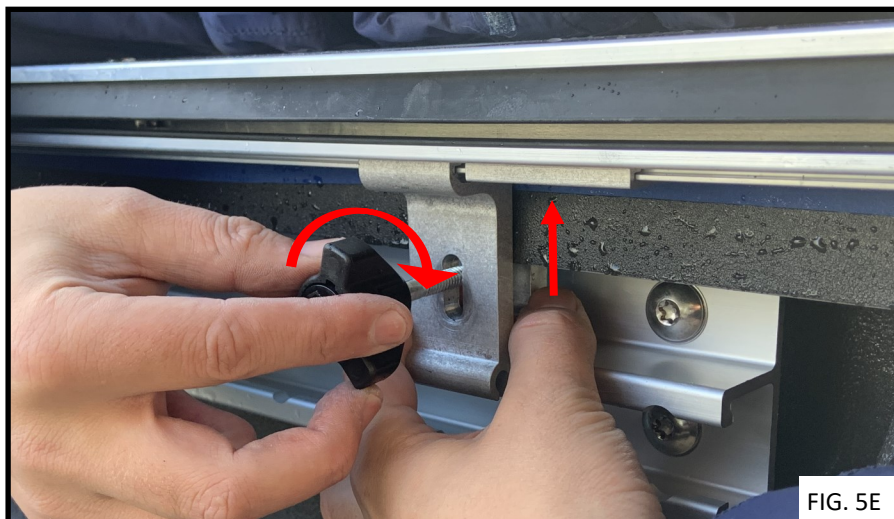

FIG. 5E

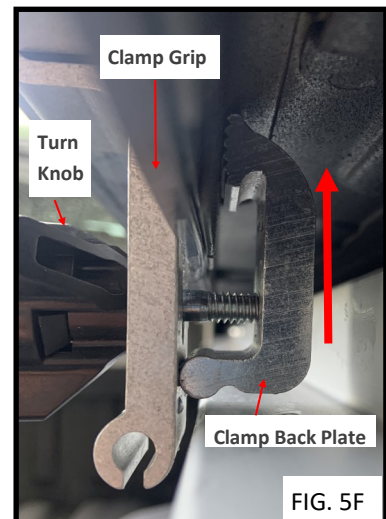

FIG. 5F

STEP 6: INSTALLING THE KICKSTANDS

The Clamp Kickstands are not compatible with the factory Cargo Management System.

Install the kickstands at the tailgate ends of the rails (FIG. 6A). Loosely fasten the kickstand assembly to the clamp grip, on the side of the grip where the pivot foot will land on the flattest section of the bed wall. Rotate the assembly so that the kickstand will push as squarely as possible against the bed wall, then tighten the wing nut. If the assembly is not positioned squarely against the bed wall, the assembly will rotate out of position, or the foot or knob can dislodge when the rail is flexed or loaded (FIG. 6B).

Run the adjusting bolt inward toward the bed wall, putting some pressure on the foot. Continue running the bolt inward using the knob until the rail is visually level. The adjusting bolt can be removed and the base flipped 180 degrees to adjust for varying clearance with the bed wall (FIG. 6C).

Verify the BR Dimension after the rails are leveled (STEP 5, FIG. 5A & FIG. 5B)

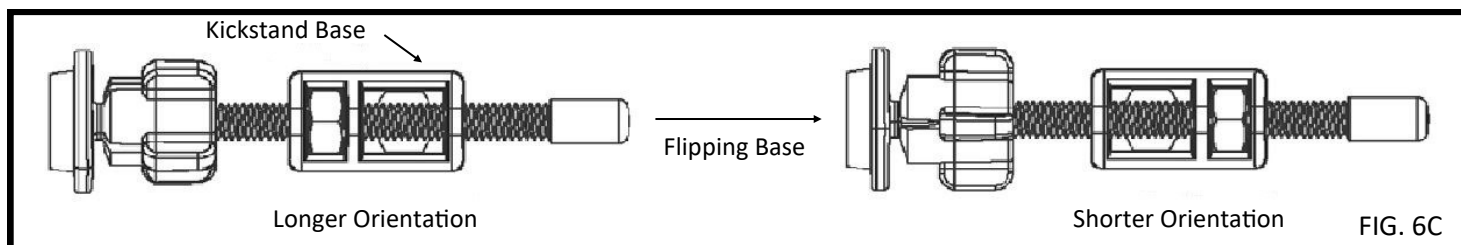
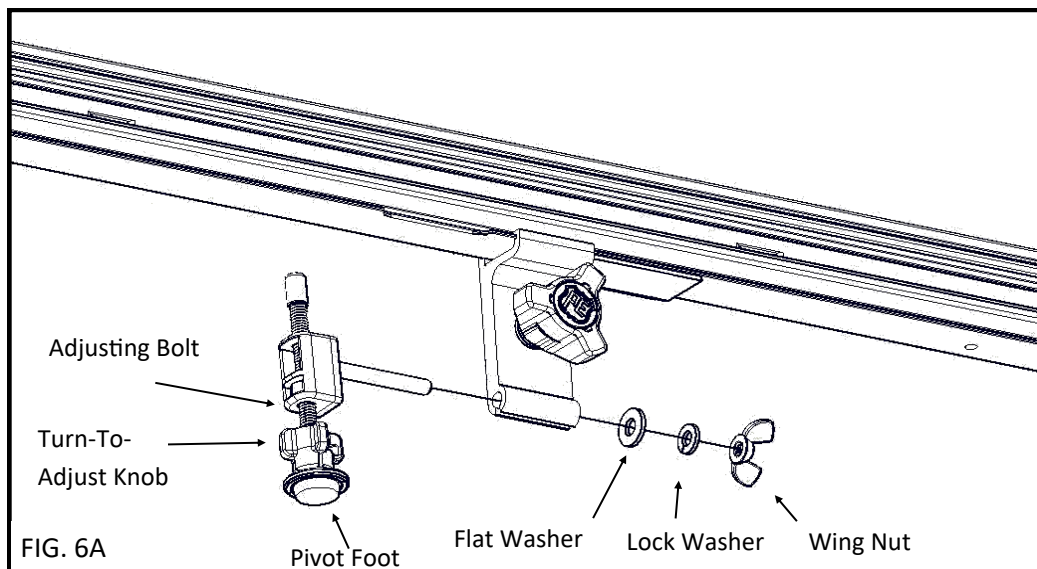

STEP 7: LUBRICATING & PLACING THE SWEEP SEALS

Locate the sweep seals (rubber weather strips) on the rails. Use the provided UV protectant to wipe the underside of the sweep seal and the top of the wear strip on each rail. The UV protectant can be found adhered to the underside of the top cover lid or in the hardware pack.

Extend the cover to the tailgate. Use an Allen Wrench if needed to carefully draw out the sweep seal (seal should be angled outwards toward the cover—not rolling in toward the bed rail). (FIG. 7A)

Proper care and placement of the sweep seal will ensure smooth operation of the cover. Alcohol, petroleum or silicone based cleaners should be avoided and ARE NOT recommended for our covers.

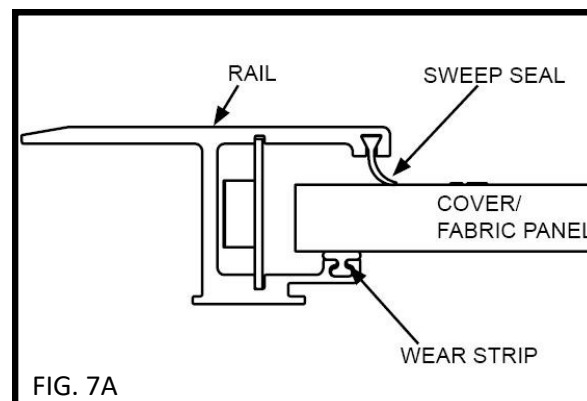

STEP 8: INSTALLING THE DRAIN TUBES

First, ensure that the Foam Washer is in place on the Drain Fitting as this washer will help prevent water leakage. Next, test fit the drain tube to determine the length you want to trim it. Always caution on the long side. Trim the end that will be inserted through the truck bed using the wire cutters or a utility knife.

With the cover opened, insert the drain tube fittings into the pre-drilled holes on the underside of the canister by pushing them in place from under the canister. The Drain Fitting should click into place.

Place the other end of the drain tube through the plastic/rubber access port or through the pre-drilled holes in the floor or the front wall of the truck bed. If routing through the front wall, ensure that the drain tubes are inserted and directed down so the water flows out of the truck bed.

To remove the drain tubes reach under the canister, grab the drain tube fitting and turn it while applying light downward pressure. When the retaining tabs align with the notches in the bottom of the canister the Drain Tube and Fitting will drop out.

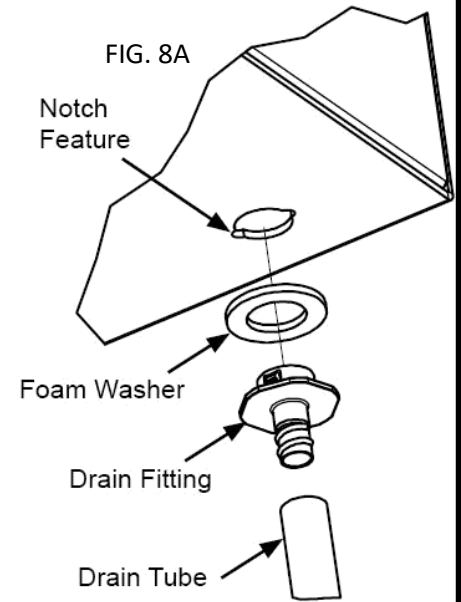

STEP 9: ATTACHING TOP COVER & VELCRO TO PULL-STRAP

HARDWARE USED:



4" Velcro Strip



Black Top Cover Screw x2

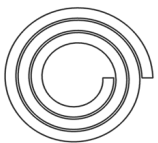

Top Cover Foam

Place the Top Cover on the canister and install with the two Black Top Cover Screws into the cover mounting blocks.

If there's a gap between the foam on the underside of the installed Top Cover and the front sill of the truck bed, use the extra roll of foam included in the kit to close the gap. Note the location where the existing foam on the Top Cover will land on the front sill of the bed, remove the Top Cover, apply the foam to the front sill of the bed, trim the foam even with the plastic rail caps, and re-install the Top Cover.

Retract the cover to the fully open position. Attach the 4" Velcro Strip onto the Velcro already attached to the pull-strap. Pull the pull-strap over to the driver or passenger side rail and remove the tape from the 4" Velcro Strip. Apply the Velcro Strip onto the underside of the rail at your desired position. This will hold the pull-strap off of the floor and out of the way when cargo is being stored in the truck bed.

Alternately, attach your pull-strap to either of the clamps (left or right side) at the tailgate end of the rails by looping it through the assembly and pressing the two Velcro strips together. This will ensure the pull-strap will always be within easy reach when trying to close the cover.

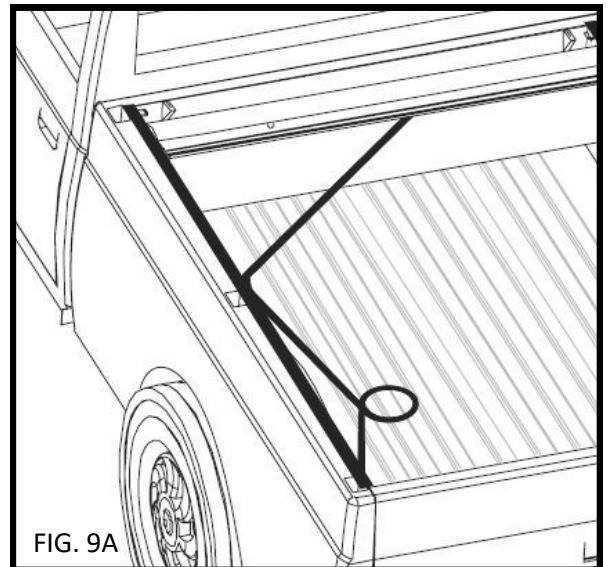

You have now completed the installation of your JackRabbit Series tonneau cover!
If you have any questions, please do not hesitate to call us at (800) 338-3697 Ext 1 to speak with our Technical Service Department.

OPERATING INSTRUCTIONS

1. To open the cover, turn the actuator knob clockwise 90 degrees until it clicks in the open position. This retracts the latches into the handle and the cover is free to roll open into the canister. A tug on the pull-strap will release the latch and allow the cover to lock into the rails.
2. To latch the cover in one of the mid-range positions, pull it back just beyond the position desired and allow the cover to retract until it latches into place. Latching positions are located every 12 inches along the rails. The clicking sound is the spring-loaded latches mounted inside the handle. The latches are designed to bypass the latching positions as the cover is being closed and to stop the cover as it is being retracted.
3. To close the cover, pull on the strap to draw it back toward the tailgate. When it is within easy reach, grasp the handle by the hand grip and pull the cover to the latching position against the tailgate.
4. To use the key lock, position the cover on the truck bed with the actuator knob in the closed position and turn the key.

HELPFUL MAINTENANCE HINTS

To help keep the JackRabbit Series tonneau cover looking its best, we recommend washing it the same as caring for your truck finish. However, you should not wax your cover. Using a citrus-based vinyl cleaner and UV Protectant will keep your cover looking like new.

To assure quiet, smooth operation, periodically apply a generous amount of UV Protectant to a rag and wipe out the inside of the rails, the underside of the sweep seals, and the top of the wear strips. Repeat as needed until these components are cleaned of debris and well lubricated.

Ensure proper placement of the sweep seal as shown in Step 7. Re-apply protectant/lubricant if the cover begins squeaking or sticking during use. (FIG. H1).

Alcohol, petroleum or silicon based cleaners should be avoided and ARE NOT recommended for our covers.

It is important to open and close the cover regularly. The spring that operated the cover is self-lubricating and regular use assures that it stays in proper working condition.

Periodically remove the Top Cover and clean out the inside of the canister.

Drain tubes may become clogged overtime and should be removed and cleaned. To remove the Drain Tubes reach under the canister, grab the Drain Tube Fitting and turn it while applying light downward pressure. When the retaining tabs align with notches in the bottom of the canister the Drain Tube and Fitting will drop out.

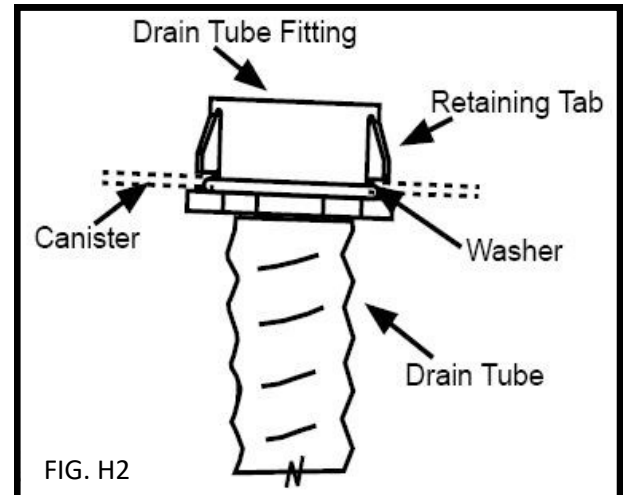
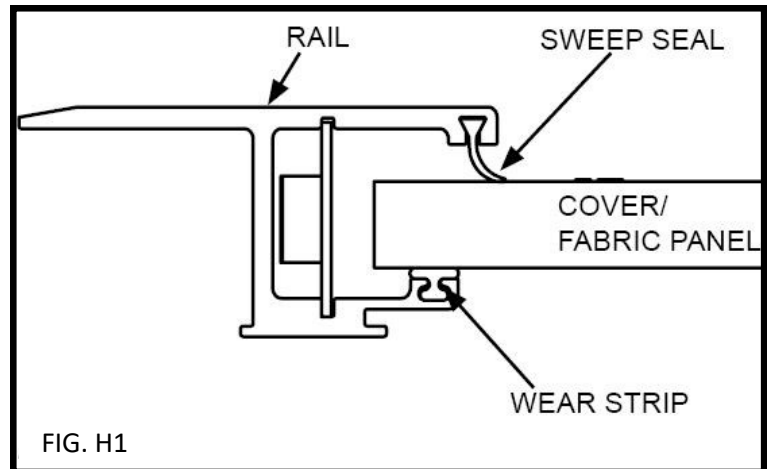

**ULTRAGROOVE™ METAL
FULL-METAL™ JACKRABBIT®
FULL-METAL JACKRABBIT MATTE
ULTIMATE LIFETIME WARRANTY**

This limited lifetime warranty covers: Failure of materials and workmanship. Warranty replacement will be issued at no cost for the life of the cover to the original owner on original vehicle – nontransferable.

- Separation of the UltraGroove Metal/Full Metal JackRabbit/ Full Metal JackRabbit Matte deck panels
- All lock assemblies
- All hardware and components

**ULTRAGROOVE ELECTRIC
BEDLOCKER®/BEDLOCKER MATTE**

For a period of seven (7) years from the date of purchase the Pace - Edwards electric retractable cover has the following limited warranty:

- Failure of materials and workmanship
- Separation of the UltraGroove Electric/BedLocker/BedLocker Matte deck panels
- Failure of the UltraGroove Electric/BedLocker/BedLocker Matte drive system and electrical components
- All hardware and components
- Warranty will be prorated after five (5) years

**ULTRAGROOVE
JACKRABBIT/JACKRABBIT MATTE**

For a period of five (5) years from the date of purchase, the cover will have the following limited warranty:

- Delamination of the ArmorTek deck
- Failure of the Continuous Tension Spring
- All lock assemblies
- All hardware and components

SWITCHBLADE™/SWITCHBLADE METAL

For a period of two (2) years, the cover will have the following limited warranty:

- Delamination of the ArmorTek deck material
- Failure of the Continuous Tension Spring
- All hardware and components

EXCLUSIONS (ALL MODELS):

- Normal wear and tear over the life of the Pace Edwards cover (including fading or discoloration)
- Water intrusion at any location or any damage caused as a result
- Additional installed parts and accessories
- Acts of nature such as tornadoes or hurricanes, or other external causes

ITEMS WHICH WILL VOID WARRANTY:

- Use of lubrication other than prescribed in owners/ installation manual
- Misuse, negligence, or accident
- Improper installation of product
- Failure to adequately secure cargo to prevent damage to the Pace Edwards cover
- Installation of parts or accessory which may interfere with the Pace Edwards cover without written permission of Pace Edwards
- Additional installed parts and accessories
- Acts of nature such as tornadoes or hurricanes, or other external causes

CONDITIONS AND LIMITATIONS:

- Any part of the Pace Edwards retractable cover found to be defective under the terms of the warranty will be repaired or replaced, at the discretion of Pace Edwards.
- Pace Edwards will have the final decision if the part in question is defective.
- Pace Edwards has no responsibility with regards to installation by its dealers or agents.
- Pace Edwards does not, under any circumstances, assume response ability for loss of item, revenue, inconvenience, or other consequential damage including, but not limited to, expenses for telephone, food, lodging, travel, loss, or damage to the vehicle the cover is installed upon, or loss or damage to personal property of the purchaser or user of the product.
- Pace Edwards will not accept any responsibility to any purchaser for warranty expressed or implied by any of its dealers, distributors, or agents.
- Pace Edwards reserves the right to make changes in the design of, improvements to, or warranty of its products without imposing any obligation for any products manufactured.
- Under no circumstances will Pace Edwards be liable for special, indirect, incidental, or consequential damages incurred in connection with any Pace Edwards retractable cover or its accessories.

Effective February 20, 2023

WARRANTY REGISTRATION: Please return this form within 14 days of purchase to:
PACE-EDWARDS • Attn: Warranty Dept. • 2400 Commercial Blvd. • Centralia, WA 98531
OR register online at www.pace-edwards.com

Name _____

Address _____

City _____ State _____ Zip _____

Vehicle Year _____ Make _____ Model _____

Model Number _____ Serial Number _____

Email _____ Phone _____

Date of Purchase _____ Purchased From _____ Price Paid _____

Customer Signature _____



(800) 338-3697 toll free

(360) 736-9992 fax

www.pace-edwards.com

Pace Edwards Company
2400 Commercial Blvd
Centralia WA 98531