

JACKRABBIT SERIES

RETRACTABLE TRUCK BED COVERS

DODGE RAM INSTALLATION INSTRUCTIONS

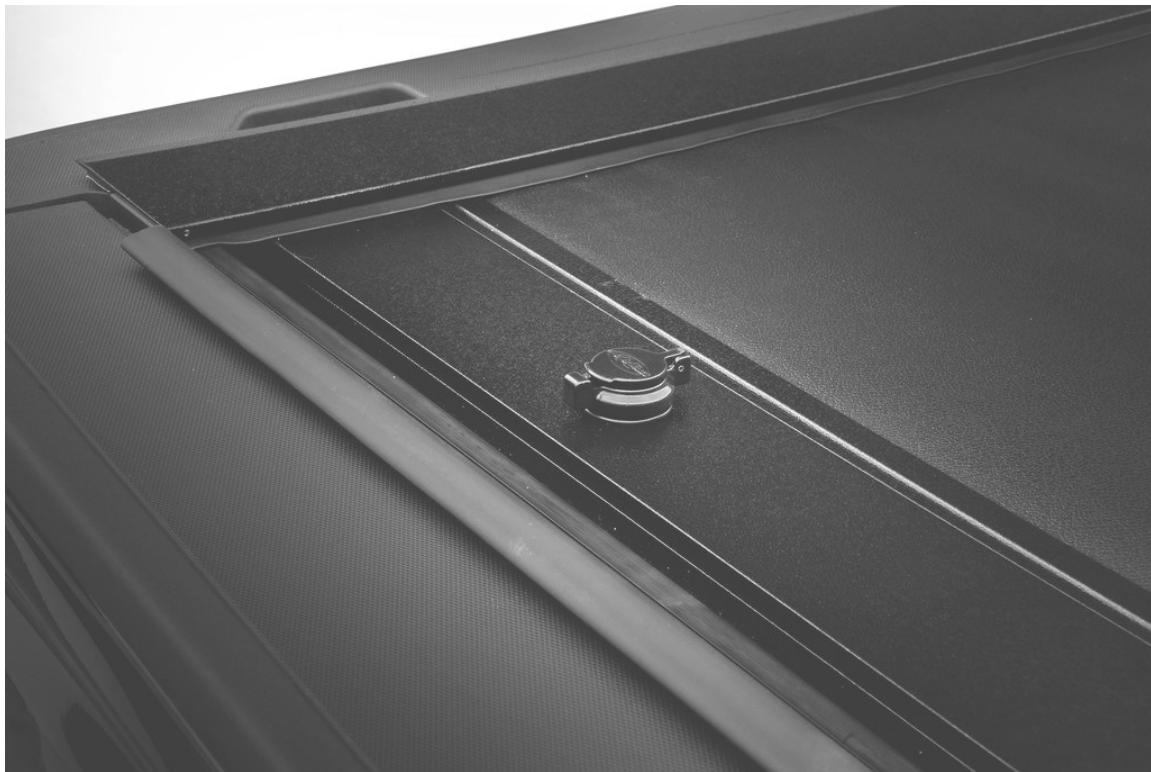

(800) 338-3697 toll free
(360) 736-9992 fax

www.pace-edwards.com

Pace Edwards Company
2400 Commercial Blvd
Centralia WA 98531

TABLE OF CONTENTS

Tools Required for Assembly	2
Before You Start	2
Drain Hole Locations	2
1. Remove Packaging Plywood & Hardware Packaging	2
2. Positioning Canister	3
3. Installing Rails	3
4. Repositioning Canister	3
5. Installing Rail Support Shims.....	4
6. Installing Clamps and Pull Strap.....	5
7. Installing Kickstands	6
8. Lubricating & Placing Sweep Seals	6
9. Installing Drain Tubes	7
10. Installing Top Cover & Velcro	7
Operating Instructions	8
Helpful Maintenance Hints	8

JRD1-2302

TOOLS REQUIRED FOR ASSEMBLY:

3/8" Wrench or Socket
#2 Phillips Screwdriver

Tape Measure
Side Cut Pliers

Masking Tape

Note: There should be no drilling into the truck body needed on most standard or full-size trucks.

BEFORE YOU START:

Read the instructions carefully before you start. These instructions are written for one-person installation. We have briefly noted where having an extra person's assistance can make installation easier.

If you have questions regarding the installation of your new retractable tonneau cover, please call our Technical Support Line at (800) 338-3697 Ext #1.

DRAIN HOLE LOCATIONS:

The JackRabbit is designed to carry rainwater from the cover into the canister and then out through the drains. Most truck models have standard OE drain holes or plastic/rubber access ports in the front of the truck bed. Check to make sure your truck has the OE drain holes so that drilling into the sheet metal is not required. If drilling is necessary, be sure to check the underside of the truck bed for the best location. The holes should be located near the side and as far forward as possible. Use a drill bit suitable for sheet metal (such as a taper drill or step drill). Drill drain tube clearance holes at 3/4" (19mm). This will need to be done before installing the cover.

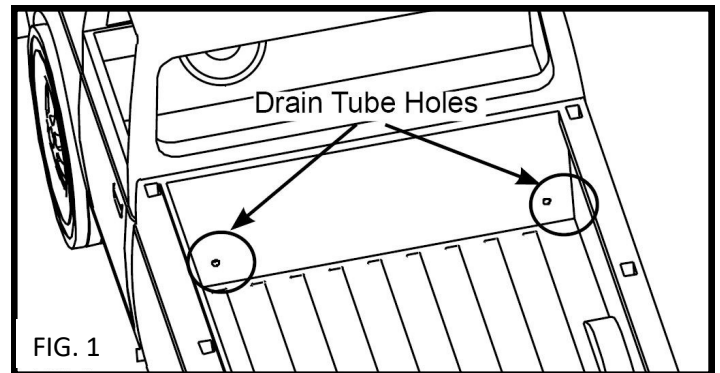

STEP 1: REMOVE PACKAGING PLYWOOD & HARDWARE

Remove the canister from box. Using the 3/8" wrench or socket remove the 2 bolts holding the plywood on the ends of the canister. **DISCARD PLYWOOD PACKAGING AND BOLTS!**

DO NOT USE A KNIFE TO OPEN THE RAIL BOX!

CAUTION!

OPEN THE RAIL BOX ALONG THE LENGTH OF THE BOX, THEN LIFT THE RAILS OUT TO AVOID SCRATCHING THE SURFACE OF THE RAILS ON THE PACKAGE STAPLES!

CAUTION!

PACKAGING CONTENTS

Complete Canister Assembly

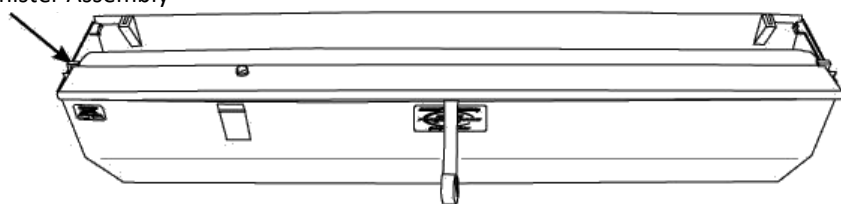

Drain Tubes

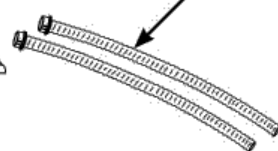

In separate Rail box Rails (left & right)



Top Cover

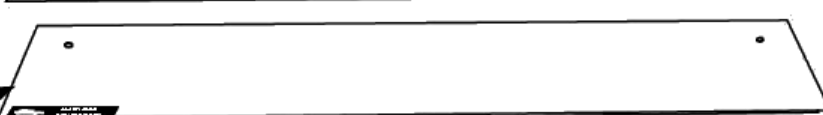

Hardware Pack



Clamp Pack



INSTALL TIP!

IF YOU HAVE ANOTHER PERSON TO HELP STEADY THE CANISTER, IT MAY BE EASIER TO INSTALL THE RAILS (DESCRIBED IN STEP 3) BEFORE POSITIONING THE CANISTER IN THE TRUCK BED.

INSTALL TIP!

STEP 2: POSITIONING THE CANISTER

Remove the top cover from the canister box and set it aside for later installation.

Perform a quick inventory to ensure all the parts are there. Be sure to check inside the small cardboard box for parts.

You will need one or two support pieces (We suggest using the top of the box the JackRabbit was shipped in) to set in the truck bed approximately one foot from the cab that will go under the canister, raising the top of the canister above the bed rails by 2-3 inches.

Remove the Canister from the box and set it on the support(s) in the truck bed.

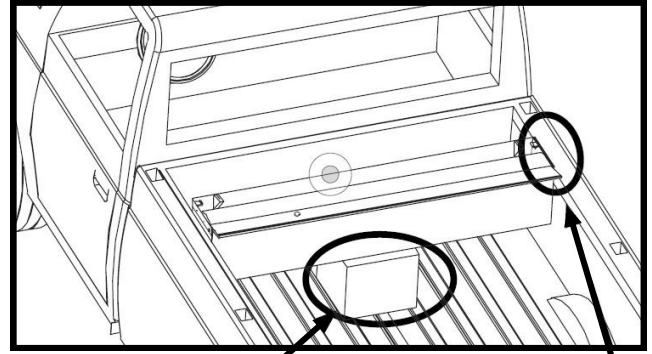

Support Piece

Top of Canister should clear Truck Bed Rails by 2-3"

STEP 3: INSTALLING RAILS

HARDWARE USED:



1/4-20 x 3/4" BOLT x2



1/4" LOCK WASHER x2



1/4" FLAT WASHER x2

Open the rail box along the length of the box; lift rails out to avoid scratching the rail surface on the package staples.

REMOVE THE PROTECTIVE PAPER ON UNDERSIDE OF RAILS. THIS IS FOR PACKAGING PURPOSES ONLY!

Install the rails by sliding them through the attached blanket guides on the canister. Threading the blanket in the rails, and sliding the rails into the rail grips that are attached on the inside of the canister.

Then slide the rails forward, towards the truck cab making sure that both of the rail grips are engaged (Fig 3A).

Secure the rail by installing the hardware (Bolt, Lock Washer & Flat Washer) through the Rail Grip Attachment and pre-drilled hole in the rail.

Complete for both left and right rails.

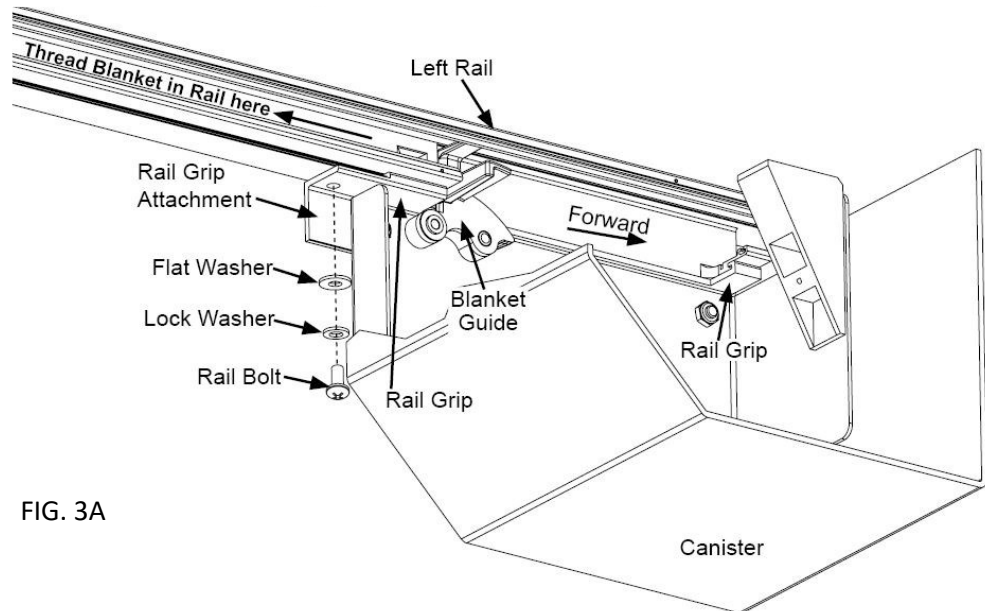

FIG. 3A

STEP 4: RE-POSITIONING THE CANISTER

Remove the support(s) under the canister so that the canister and rails rest firmly on the sides of the truck bed. With the tailgate closed, position the rails so they are 1/16" away from tailgate.

STEP 5: INSTALLING RAIL SUPPORT SHIMS

Once you have the position of the rails set from step 4, check to see if you are happy with the level of the rails at the cab end (FIG. 5A). If you are happy with the level of the rails you can move on to the next step. If the rails are tipped down, mark where the front of the rails sit on the truck with masking tape (this will save your cover location). Then open the tailgate and slide the canister and rails back a few inches.

There are 2 x 1/16" white shims and 2 x 1/8" black shims in your comp kit. Add shims to bulkhead of the canister (FIG. 5B) until you reach your preferred rail angle. When you are satisfied with your shim selection you can slide the rails to your masking tape mark, remove the tape, and move on to the next step.

FIG. 5A

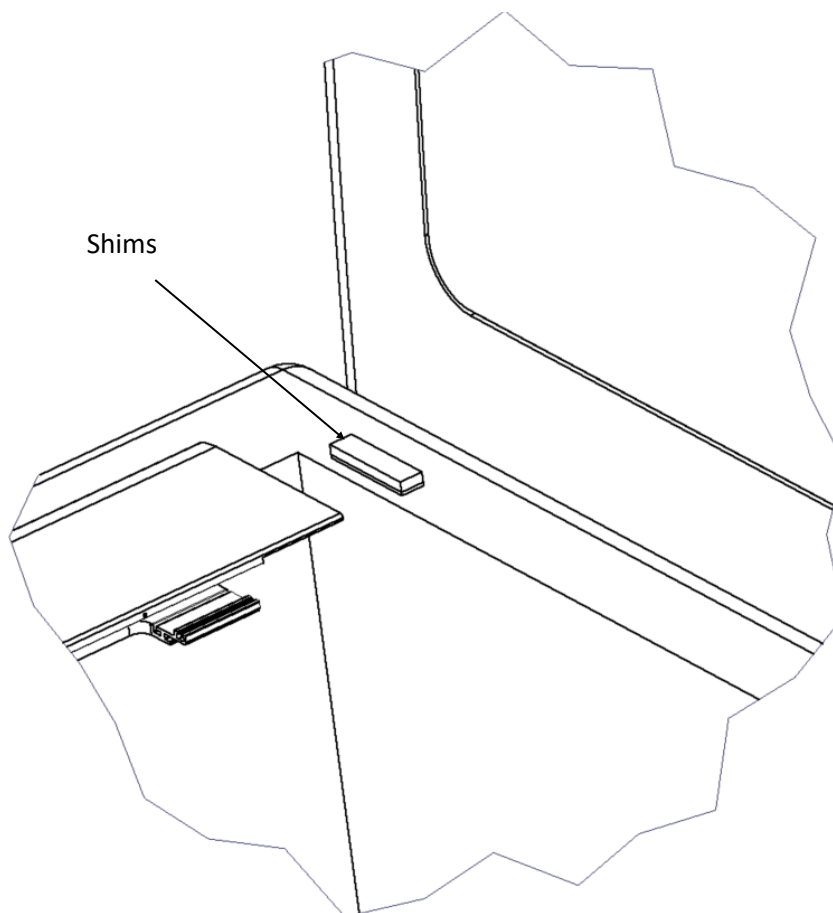
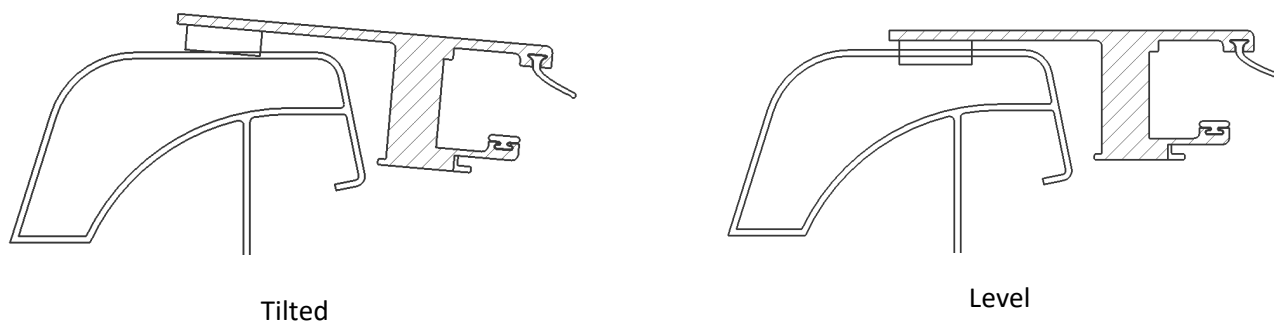

FIG. 5B

STEP 6: INSTALLING THE CLAMPS

Secure the rails to the truck bed by installing two clamp assemblies per rail. Slide the Clamp Grip onto the Rail at the Clamp Relief and then slide it towards the Rail Bracket and Shim (Fig 6E and 6F). Then assemble the rest of the clamp parts as shown below (Fig 6C & 6D). Slide the Pivot Arm in from the canister side to avoid any interferences. Be sure to use the long clamp grip at the canister end (FIG 6D) and the shorter clamp grip at the tailgate end (FIG 6C).

Before tightening the rail clamps, set the Rail End Caps about 1/16" from the tailgate. This space will allow for overstroke when closing the tailgate. Once everything is square, tighten the Rail clamps completely but **do NOT tighten over 120 inch-pounds!**

Finally, check for proper spacing by measuring between the rails at the canister and the tailgate end of the rails (Fig 6A). The measurement should be equal to or less than those in Fig 6B. The Rail Brackets and Shims have been pre-installed to achieve the proper Between the Rail dimensions (BR) when placed on an average factory truck bed. However, not all truck beds are average dimensionally and some have optional plastic caps or over the rail spray-in bedliners.

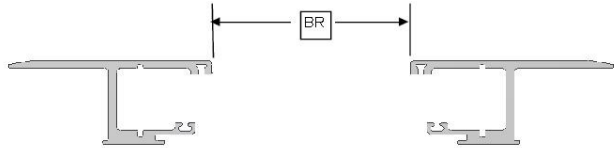

FIG. 6A

Part number is on the serial number label in the upper-left corner of the canister (looking from tailgate).

PART NUMBER	BETWEEN THE RAILS (BR)
FM and TR 2022	59 1/16
FM and TR 2023	59 1/16
FM and TR 2077	58 3/16
FM and TR 2078	58 13/16
FM and TR 2079	58 13/16
FM and TR 2124	58 3/16
FM and TR 2125	58 3/16

FIG. 6B

Another way to ensure proper fit is to check the side to side play of the handle assembly at the canister and at the tailgate end of the rails. There should be, at minimum, enough play to allow the cover to move freely with no drag and at a maximum 1/8" per side. More than 1/8" per side may result in the cover opening unintentionally and in severe cases it may fall between the rail tracks and damage the cover. **There are shims on the brackets that can be removed if the unit is too tight and shims in the hardware pack that can be added if too loose.**

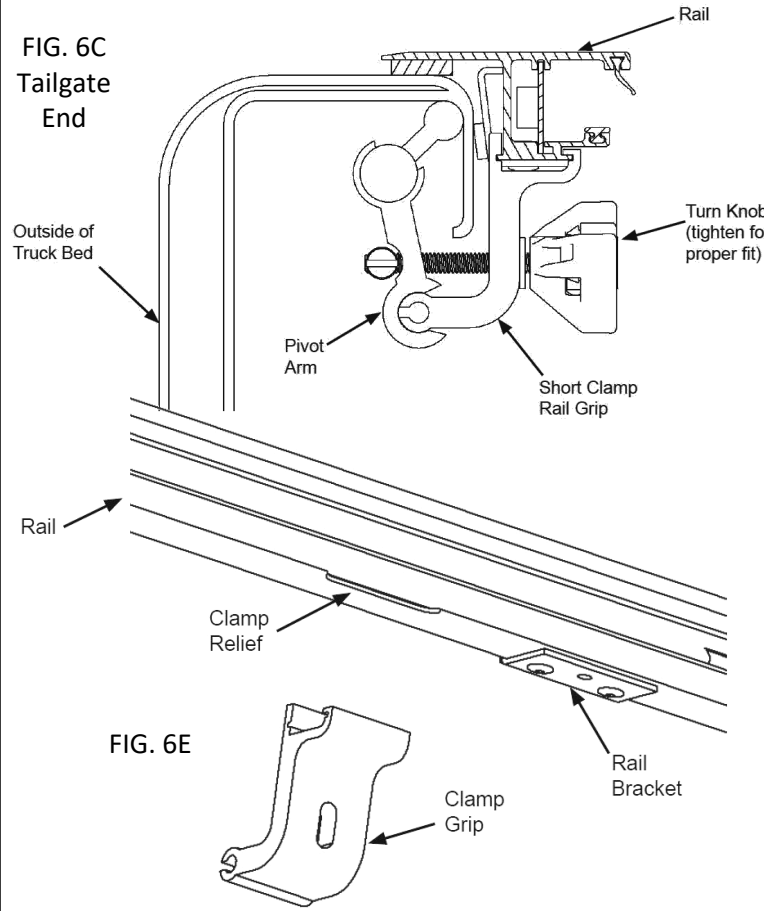

FIG. 6C
Tailgate End

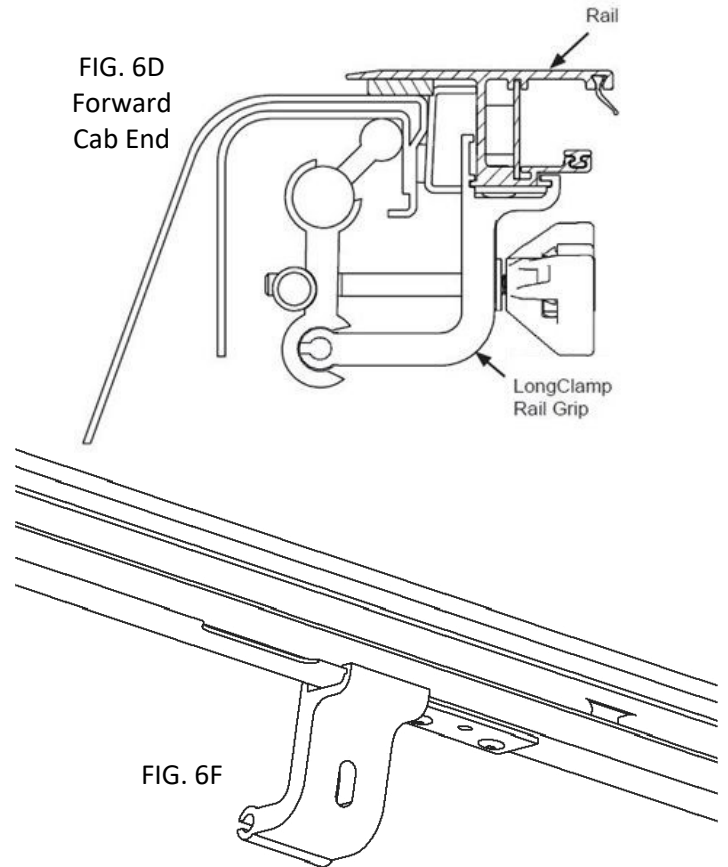

FIG. 6D
Forward Cab End

FIG. 6F

STEP 6 - Continued: ATTACH THE PULL-STRAP

Attach your pull-strap to either of the clamps (left or right side) at the tailgate end of the rails by looping it through the assembly and pressing the two Velcro strips together. This will ensure the pull-strap will always be within easy reach when trying to close the cover.

STEP 7: INSTALLING THE KICKSTANDS

Install the kickstands at the tailgate ends of the rails (FIG. 7A). Loosely fasten the kickstand assembly to the clamp grip, on the side of the grip where the pivot foot will land on the flattest section of the bed wall. Rotate the assembly so that the kickstand will push as squarely as possible against the bed wall (FIG. 7B), then tighten the wing nut. If the assembly is not positioned squarely against the bed wall, the assembly will rotate out of position, or the foot or knob can dislodge when the rail is flexed or loaded (FIG. 7C).

Run the adjusting bolt inward toward the bed wall, putting some pressure on the foot. Continue running the bolt inward using the knob until the rail is visually level. The adjusting bolt can be removed and the base flipped 180 degrees to adjust for varying clearance with the bed wall (FIG. 7D). Verify the BTR dimension after the rails are leveled (STEP 6, FIG 6A & 6B).

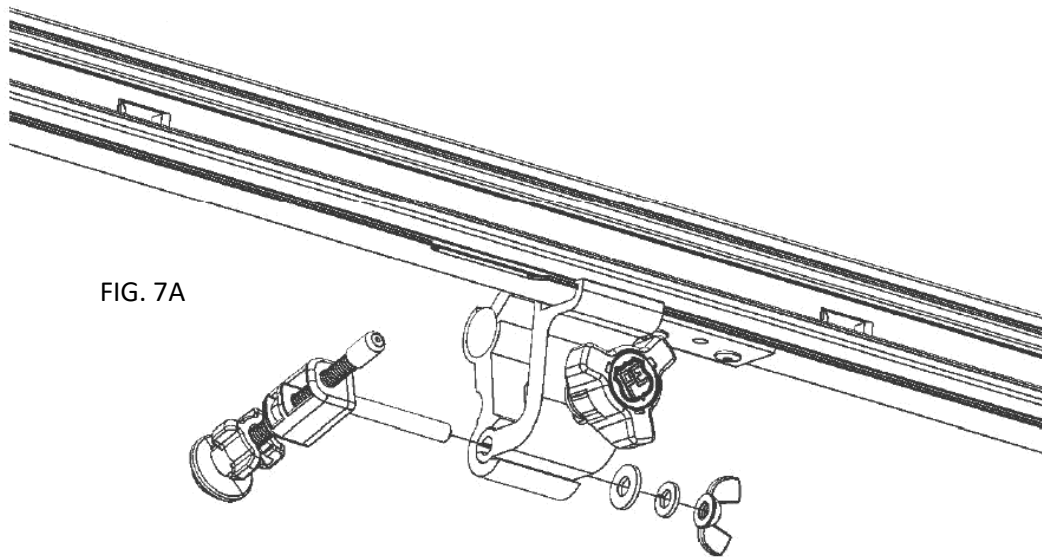

FIG. 7A

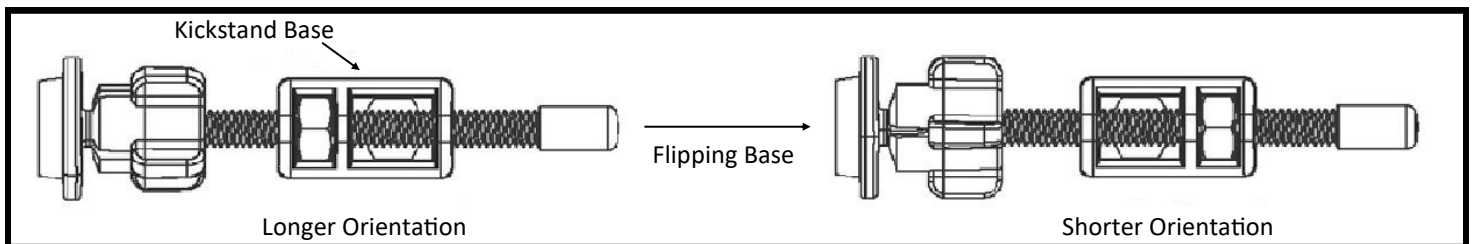

FIG. 7B



FIG. 7C

FIG. 7D



STEP 8: LUBRICATING & PLACING THE SWEEP SEALS

Locate the sweep seals (rubber weather strips) on the rails. Use the provided UV protectant to wipe the underside of the sweep seal and the top of the wear strip on each rail. The UV protectant can be found adhered to the underside of the top cover lid or in the hardware pack.

Extend the cover to the tailgate. Use an Allen Wrench if needed to carefully draw out the sweep seal (seal should be angled outwards toward the cover—not rolling in toward the bed rail). (Fig 8A)

Proper care and placement of the sweep seal will ensure smooth operation of the cover. **Alcohol, petroleum or silicone based cleaners should be avoided and ARE NOT recommended for our covers**

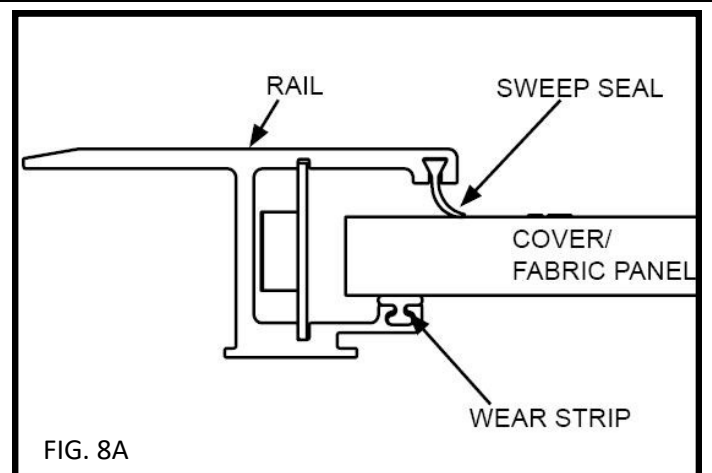

FIG. 8A

STEP 9: INSTALLING THE DRAIN TUBES

First, ensure that the Foam Washer is in place on the Drain Fitting as this washer will help prevent water leakage. Next, test fit the drain tube to determine the length you want to trim it. Always caution on the long side. Trim the end that will be inserted through the truck bed using the wire cutters or a utility knife.

With the cover opened, insert the drain tube fittings into the pre-drilled holes on the underside of the canister by pushing them in place from under the canister. Drain Fitting should click into place.

Place the other end of the drain tube through the plastic/rubber access port or through the pre-drilled holes in the floor or the front wall of the truck bed. If routing through the front wall, ensure that the drain tubes are inserted and directed down so the water flows out of the truck bed.

To remove the drain tubes reach under the canister, grab the drain tube fitting and turn it while applying light downward pressure. When the retaining tabs align with the notches in the bottom of the canister the Drain Tube and Fitting will drop out.

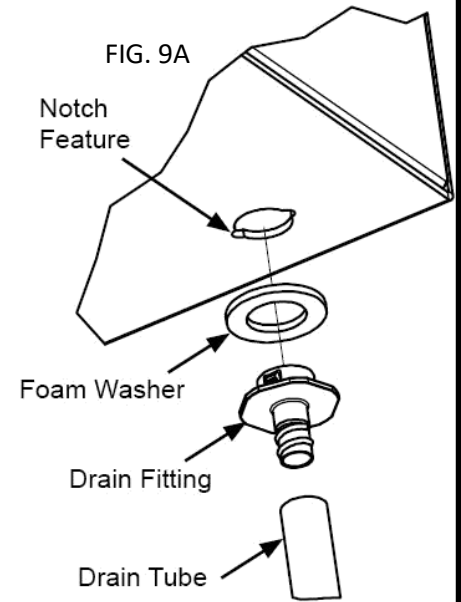

STEP 10: ATTACHING TOP COVER & VELCRO TO PULL-STRAP

HARDWARE USED:



4" Velcro Strip



Black Top Cover
Screw x2

Place the Top Cover on the canister and install with the two black Top Cover screws into the cover mounting blocks. We recommend that you use a thread locking adhesive like Loctite® on the screws.

If there's a gap between the foam on the underside of the installed Top Cover and the front sill of the truck bed, use the extra roll of foam included in the kit to close the gap. Mark the location where the existing foam on the Top Cover will land on the front sill. Remove the Top Cover, apply the foam to the front sill of the bed, trim the foam even with the plastic rail caps, and re-install the Top Cover.

Retract the cover to the fully open position.

Attach the 4" Velcro Strip onto the Velcro already attached to the pull-strap.

Pull the pull-strap over to the driver or passenger side rail and remove the tape from the 4" Velcro Strip.

Then apply the Velcro Strip onto the underside of the rail at your desired position.

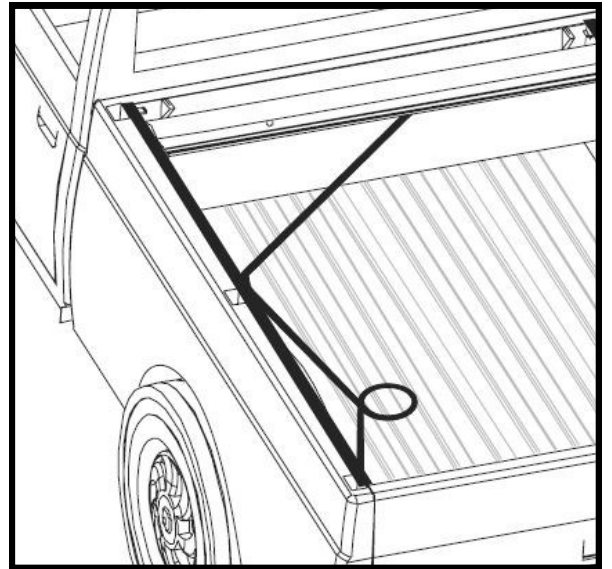

You have now completed the installation of your JackRabbit Series tonneau cover!
If you have any questions, please do not hesitate to call us at (800) 338-3697 Ext 1 to speak with our Technical Service Department.

OPERATING INSTRUCTIONS

1. To open the cover, turn the actuator knob clockwise 90 degrees until it clicks in the open position. This retracts the latches into the handle and the cover is free to roll open into the canister. A tug on the pull-strap will release the latch and allow the cover to lock into the rails.
2. To latch the cover in one of the mid-range positions, pull it back just beyond the position desired and allow the cover to retract until it latches into place. Latching positions are located every 12 inches along the rails. The clicking sound is the spring-loaded latches mounted inside the handle. The latches are designed to bypass the latching positions as the cover is being closed and to stop the cover as it is being retracted.
3. To close the cover, pull on the strap to draw it back toward the tailgate. When it is within easy reach, grasp the handle by the hand grip and pull the cover to the latching position against the tailgate.
4. To use the key lock, position the cover on the truck bed with the actuator knob in the closed position and turn the key.

HELPFUL MAINTENANCE HINTS

To help keep the JackRabbit Series tonneau cover looking its best, we recommend washing it the same as caring for your truck finish. However, you should not wax your cover. Using a citrus-based vinyl cleaner and UV Protectant will keep your cover looking like new.

To assure quiet, smooth operation, periodically apply a generous amount of UV Protectant to a rag and wipe out the inside of the rails, the underside of the sweep seals, and the top of the wear strips. Repeat as needed until these components are cleaned of debris and well lubricated.

Ensure proper placement of the sweep seal as shown in Step 8. Re-apply protectant/lubricant if the cover begins squeaking or sticking during use. (Fig H1).

Alcohol, petroleum or silicon based cleaners should be avoided and ARE NOT recommended for our covers.

It is important to open and close the cover regularly. The spring that operated the cover is self-lubricating and regular use assures that it stays in proper working condition.

Periodically remove the Top Cover and clean out the inside of the canister.

Drain tubes may become clogged overtime and should be removed and cleaned. To remove the Drain Tubes reach under the canister, grab the Drain Tube Fitting and turn it while applying light downward pressure. When the retaining tabs align with notches in the bottom of the canister the Drain Tube and Fitting will drop out.

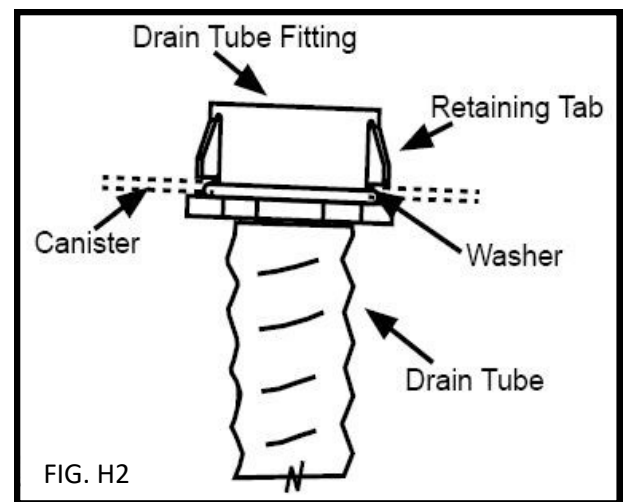
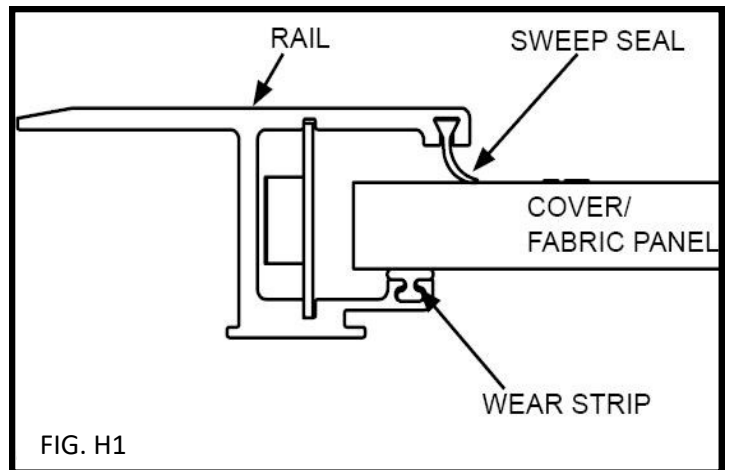

**ULTRAGROOVE™ METAL
FULL-METAL™ JACKRABBIT®
FULL-METAL JACKRABBIT MATTE
ULTIMATE LIFETIME WARRANTY**

This limited lifetime warranty covers: Failure of materials and workmanship. Warranty replacement will be issued at no cost for the life of the cover to the original owner on original vehicle – nontransferable.

- Separation of the UltraGroove Metal/Full Metal JackRabbit/ Full Metal JackRabbit Matte deck panels
- All lock assemblies
- All hardware and components

**ULTRAGROOVE ELECTRIC
BEDLOCKER®/BEDLOCKER MATTE**

For a period of seven (7) years from the date of purchase the Pace - Edwards electric retractable cover has the following limited warranty:

- Failure of materials and workmanship
- Separation of the UltraGroove Electric/BedLocker/BedLocker Matte deck panels
- Failure of the UltraGroove Electric/BedLocker/BedLocker Matte drive system and electrical components
- All hardware and components
- Warranty will be prorated after five (5) years

**ULTRAGROOVE
JACKRABBIT/JACKRABBIT MATTE**

For a period of five (5) years from the date of purchase, the cover will have the following limited warranty:

- Delamination of the ArmorTek deck
- Failure of the Continuous Tension Spring
- All lock assemblies
- All hardware and components

SWITCHBLADE™/SWITCHBLADE METAL

For a period of two (2) years, the cover will have the following limited warranty:

- Delamination of the ArmorTek deck material
- Failure of the Continuous Tension Spring
- All hardware and components

EXCLUSIONS (ALL MODELS):

- Normal wear and tear over the life of the Pace Edwards cover (including fading or discoloration)
- Water intrusion at any location or any damage caused as a result
- Additional installed parts and accessories
- Acts of nature such as tornadoes or hurricanes, or other external causes

ITEMS WHICH WILL VOID WARRANTY:

- Use of lubrication other than prescribed in owners/ installation manual
- Misuse, negligence, or accident
- Improper installation of product
- Failure to adequately secure cargo to prevent damage to the Pace Edwards cover
- Installation of parts or accessory which may interfere with the Pace Edwards cover without written permission of Pace Edwards
- Additional installed parts and accessories
- Acts of nature such as tornadoes or hurricanes, or other external causes

CONDITIONS AND LIMITATIONS:

- Any part of the Pace Edwards retractable cover found to be defective under the terms of the warranty will be repaired or replaced, at the discretion of Pace Edwards.
- Pace Edwards will have the final decision if the part in question is defective.
- Pace Edwards has no responsibility with regards to installation by its dealers or agents.
- Pace Edwards does not, under any circumstances, assume response ability for loss of item, revenue, inconvenience, or other consequential damage including, but not limited to, expenses for telephone, food, lodging, travel, loss, or damage to the vehicle the cover is installed upon, or loss or damage to personal property of the purchaser or user of the product.
- Pace Edwards will not accept any responsibility to any purchaser for warranty expressed or implied by any of its dealers, distributors, or agents.
- Pace Edwards reserves the right to make changes in the design of, improvements to, or warranty of its products without imposing any obligation for any products manufactured.
- Under no circumstances will Pace Edwards be liable for special, indirect, incidental, or consequential damages incurred in connection with any Pace Edwards retractable cover or its accessories.

Effective February 20, 2023



WARRANTY REGISTRATION: Please return this form within 14 days of purchase to:
PACE-EDWARDS • Attn: Warranty Dept. • 2400 Commercial Blvd. • Centralia, WA 98531
OR register online at www.pace-edwards.com

Name _____

Address _____

City _____ State _____ Zip _____

Vehicle Year _____ Make _____ Model _____

Model Number _____ Serial Number _____

Email _____ Phone _____

Date of Purchase _____ Purchased From _____ Price Paid _____

Customer Signature _____

©2023 Pace Edwards by LEER®