

BEDSLIDE®

2022 Toyota Tundra 8 ft.

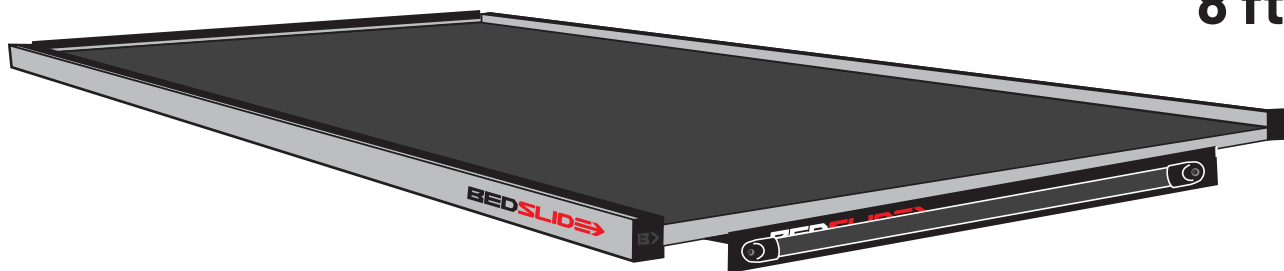

KIT CONTENTS



Heavy!
Team Lift!



Caution



Loctite 242



Discard

A

BEDSLIDE®



B

NO DRILL BRACKETS

(2) CAB END BRACKETS

(2) MID GATE BRACKETS

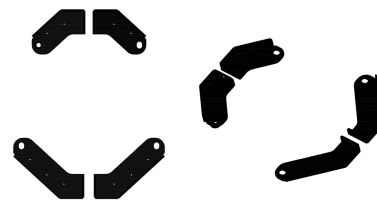

C

GUARDRAIL KIT

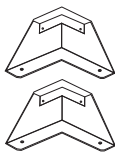

(2) CORNER TOWERS

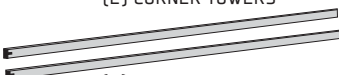

(2) GUARDRAILS

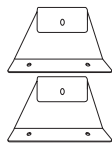

(2) SIDE TOWERS



(1) HEAD RAIL

D

HARDWARE KIT

- (1) BRACKET, NO DRILL BULKHEAD END RH TT22
- (1) BRACKET, NO DRILL BULKHEAD END LH TT22
- (1) KIT, HARDWARE FOR TUNDRA NO-DRILL BRACKETS
- (4) SPACER, NO DRILL TT22
- (4) WASHER, M12 OD 42.5mm THK 3.0mm, STEEL
- (4) SCREW, M12 X 1.25MM 120 LG
- (4) NUT, 3/8-16 SERRATED FLANGE ZINC
- (4) BOLT, CARRAIGE, 5/16"-18 X 1 1/4"
- (1) BRACKET, NO DRILL REAR END LH TT22
- (1) BRACKET, NO DRILL REAR END RH TT22



NOTE: Ensure truck bed is clean and free of any cargo prior to installation.

TOOLS REQUIRED



1/2" RATCHET



1/2" WRENCH



19MM WRENCH



T-55 TORX BIT



1/8 ALLEN KEY



5/32 ALLEN KEY



UTILITY KNIFE

NOTE: READ INSTRUCTIONS COMPLETELY BEFORE ATTEMPTING INSTALLATION.

GUARDRAIL ASSEMBLY

1 INSERT (2) MOUNT BLOCKS INTO BEDTRAX (CAB END)

Loosen set screw on one of the plastic end caps of the front (cab end) BEDTRAX using a 1/8 allen key. Remove end cap and insert (2) MOUNT BLOCKS. Re-install end cap and tighten the set screw. **These MOUNT BLOCKS will be used to secure the corner towers in the next step.**



1/8 ALLEN KEY



TIGHTEN TO MANUFACTURE SPECS, 15 INCH LBS.

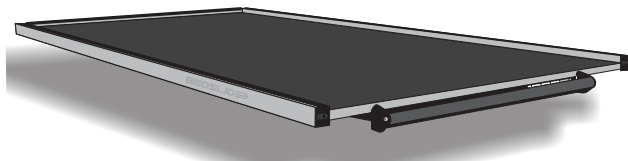

2 MOUNT CORNER TOWER

**CORNER TOWERS are positioned upside down and rest on the BEDTRAX for shipping purposes.* Loosen set screw on both of the plastic end caps located at the rear (tailgate end) of the BEDTRAX using a 1/8 allen key. Remove end caps and insert (6) MOUNT BLOCKS down each side of the BEDTRAX. Set end caps aside. Next invert CORNER TOWER, slide MOUNT BLOCKS underneath the CORNER TOWER so they line up with the mount holes. Secure using the supplied 1/4-20 x 3/4" allen head bolts in to the MOUNT BLOCKS with a 5/32 allen key.



TIGHTEN TO MANUFACTURE SPECS, 10 FT. LBS.



1/8 ALLEN KEY



5/32 ALLEN KEY

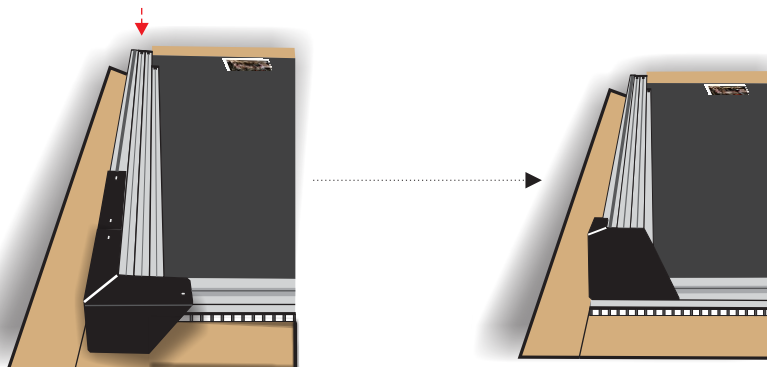
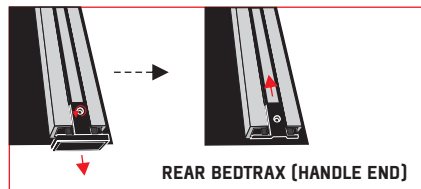

GUARDRAIL ASSEMBLY

3 MOUNT HEAD RAIL TO CORNER TOWER

Slide one end of the HEAD RAIL with slot facing forward into the mounted corner tower. Insert a MOUNT BLOCK into the HEAD RAIL and slide over to the CORNER TOWER so that the threaded hole is center with the mounting hole on the CORNER TOWER. Fasten together with a 1/4-20 x 3/4" allen head bolt with a 5/32 allen key.

 TIGHTEN TO MANUFACTURE SPECS, 10 FT. LBS.



5/32 ALLEN KEY

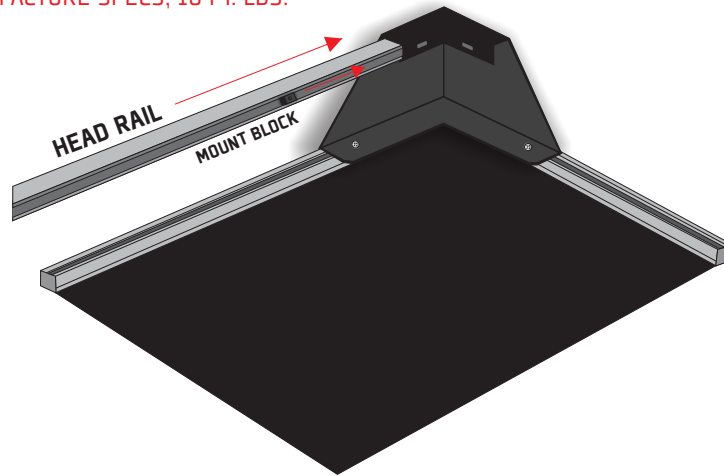

4 MOUNT CORNER TOWER (opposite side)

**CORNER TOWERS are positioned upside down and rest on the unit for shipping purposes.* Insert a MOUNT BLOCK into the aluminum HEAD RAIL then invert the CORNER TOWER and slide open end into the HEAD RAIL. Slide (2) MOUNT BLOCKS underneath the CORNER TOWER so they line up with the mounting holes. Secure the CORNER TOWER to the BEDTRAX with (2) supplied 1/4-20 x 3/4" allen head bolts with a 5/32 allen key.

 TIGHTEN TO MANUFACTURE SPECS, 10 FT. LBS.



5/32 ALLEN KEY

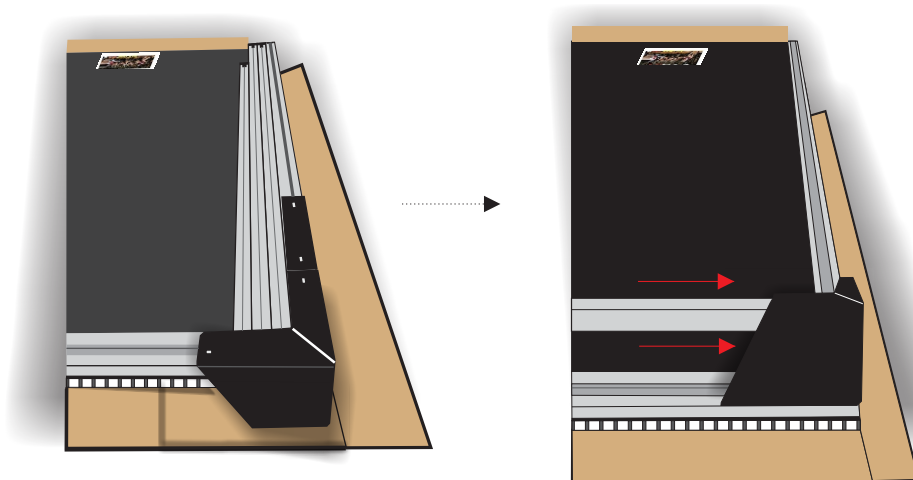

GUARDRAIL ASSEMBLY

5 MOUNT SIDE TOWERS AND (2) D-RING TIE DOWNS

**SIDE TOWERS are positioned upside down and rest on the unit for shipping purposes.*

Invert the SIDE TOWERS with the mount holes facing inward, slide (2) MOUNT BLOCKS underneath each TOWER and secure them to the BEDTRAX with the supplied 1/4-20 x 3/4" allen head bolts. **DO NOT TIGHTEN!!** *PLEASE NOTE: BEDSLIDE® recommends a D-ring tie down be mounted in front of and behind each of the SIDE TOWERS. Pre-install them before fastening the SIDE TOWERS.

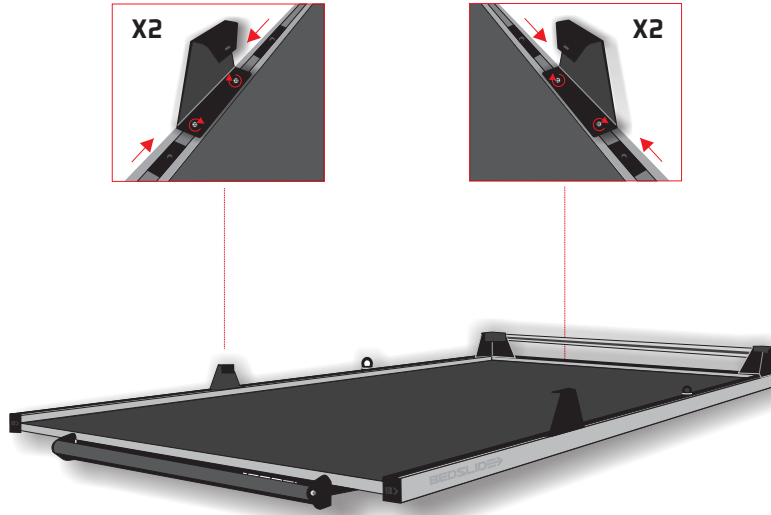

6 INSTALL GUARD RAILS (Optional on the BEDSLIDE® 1000)

Insert (2) MOUNT BLOCKS into an open end of each of the GUARD RAILS making sure they do not slide off. Then insert each GUARD RAIL into the open end of the CORNER TOWERS, slide a MOUNT BLOCK to each corner and secure with a supplied 1/4-20 x 3/4" allen head bolt. Next insert SIDE TOWERS into the closed end of the GUARD RAILS, slide a MOUNT BLOCK to the end and fasten with an allen head bolt. ***PLEASE NOTE: 6" OF THE GUARD RAIL SHOULD BE STICKING OUT PAST THE SIDE TOWER FOR A CLEAN LOOK.**

 **TIGHTEN TO MANUFACTURE SPECS, 10 FT. LBS.**



5/32 ALLEN KEY

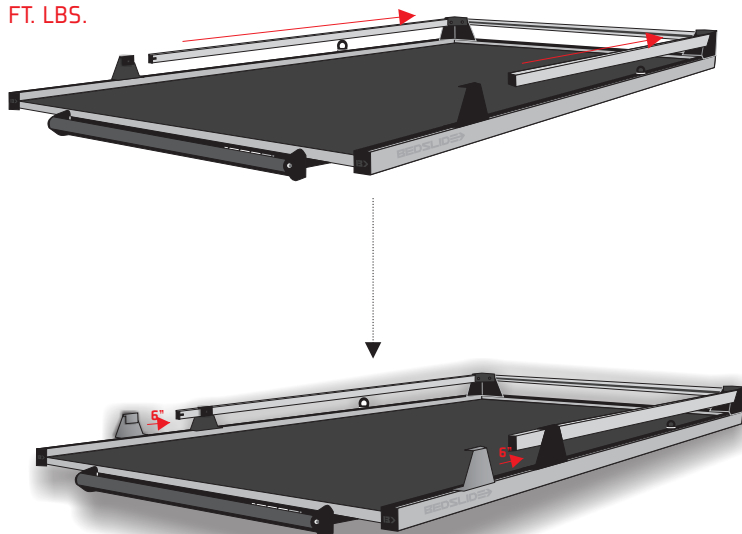

GUARDRAIL ASSEMBLY

7 INSTALL D-RING TIE DOWNS

Locate the (4) D-ring tie downs inside the install kit. Thread into the MOUNT BLOCKS you previously inserted into the BEDTRAX, position at desired location and tighten down. Lastly re-install the (2) plastic end caps and tighten the set screws with a 1/8 allen key.

THAT'S IT! YOUR BEDSLIDE® IS FULLY ASSEMBLED!

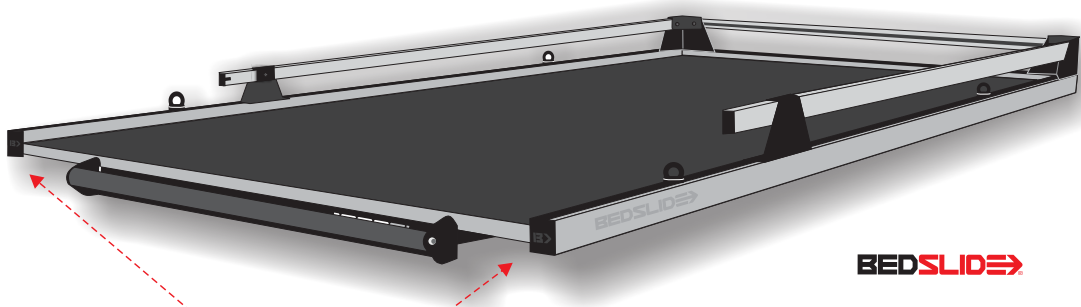

BEDSLIDE →



1/8 ALLEN KEY

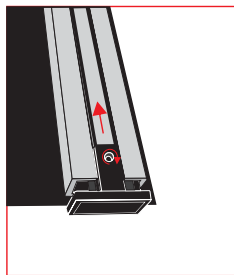

TIGHTEN TO MANUFACTURE SPECS, 15 INCH LBS.

INSTALLATION

1 SEPARATE SLIDING TOP FRAME FROM THE BASE

Fully extend the BEDSLIDE® and remove the top frame by lifting up and out.

The welded safety stops must go up and over the rear roller bearings and spacer guides in order for the top frame to release. **This step will require 2 people to help lift!**

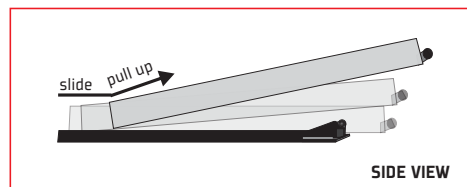
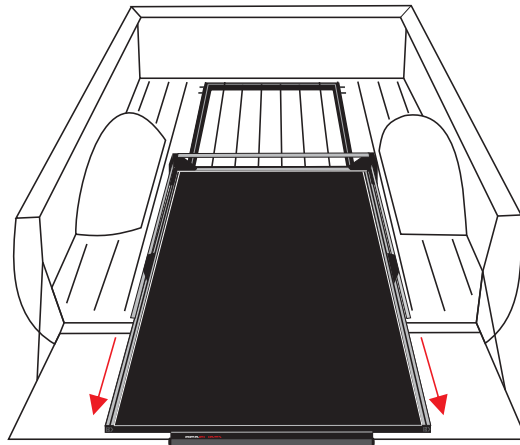

2 REMOVE SPRAY IN LINER MATERIAL

If your bed is equipped with a spray in bed liner you must cut and remove the material around the bed bolt. A 3 1/2" x 3 1/2" square is sufficient.



UTILITY KNIFE

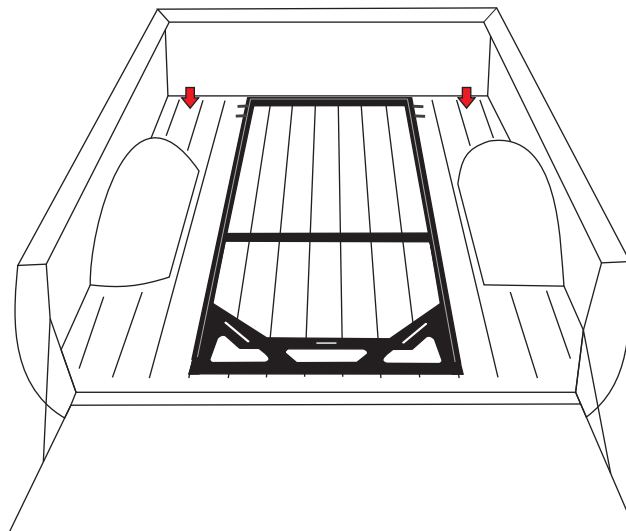

INSTALLATION

3 LOOSEN AND REMOVE CAB END BED BOLTS

Loosen and remove the cab end bed bolts using a ratchet with a T-55 torx bit. **Loosen per manufacturer specs. If your truck bed is equipped with a spray in bed liner you will need to cut around the head of each bolt with a utility knife to help break the bed bolts free.**



Discard the bed bolts.



DO NOT REMOVE ALL 4 BED BOLTS AT ONCE! Removal of all 4 bed bolts will allow the bed to move out of alignment. This will make it difficult to re-install the bed bolts.



TOP VIEW

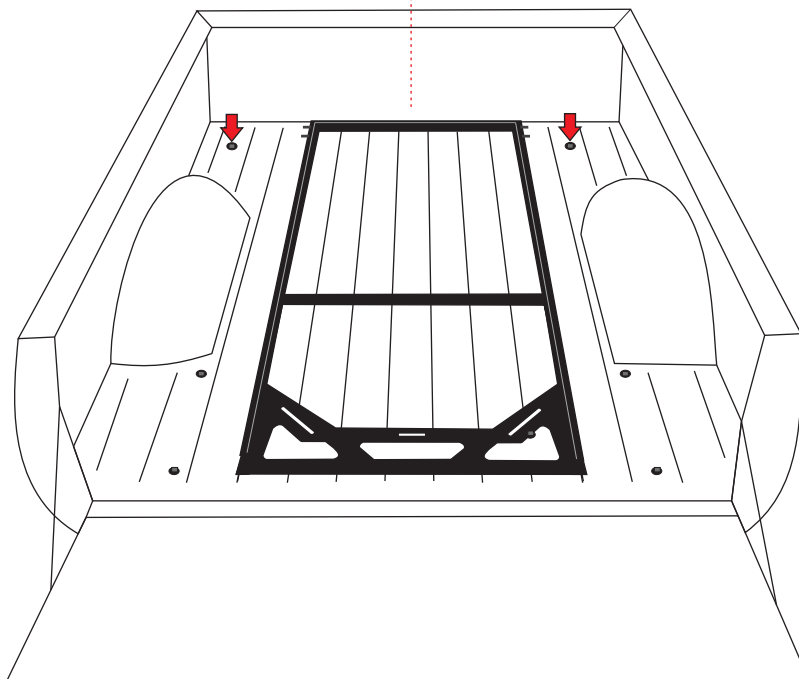
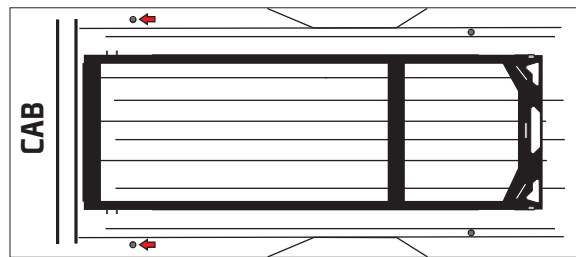

INSTALLATION

4 ATTACH FRONT (CAB END) MOUNTING BRACKETS

Attach LEFT and RIGHT mounting brackets to the threaded studs affixed to each side of the base frame. Secure each bracket with two 5/16-18 serrated flange nuts & tighten with a 1/2" wrench.

 **TIGHTEN TO MANUFACTURE SPECS, 21 FT. LBS.**

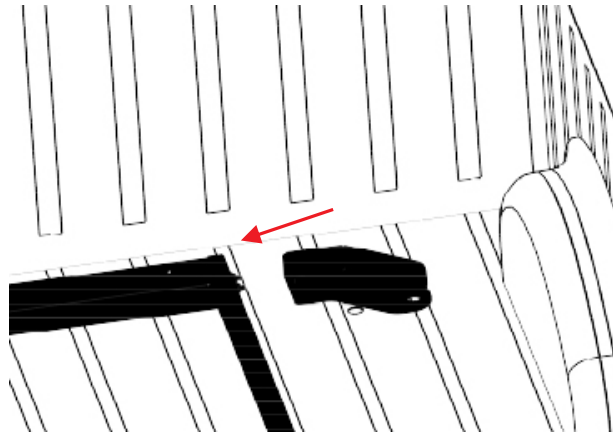

5 SECURE FRONT (CAB END) MOUNTING BRACKETS TO THE BED

Apply a small bead of Loctite® 242 to the threads of the new bed bolts and secure both the LEFT and RIGHT mounting brackets directly to the bed.

 **DO NOT TIGHTEN!!**

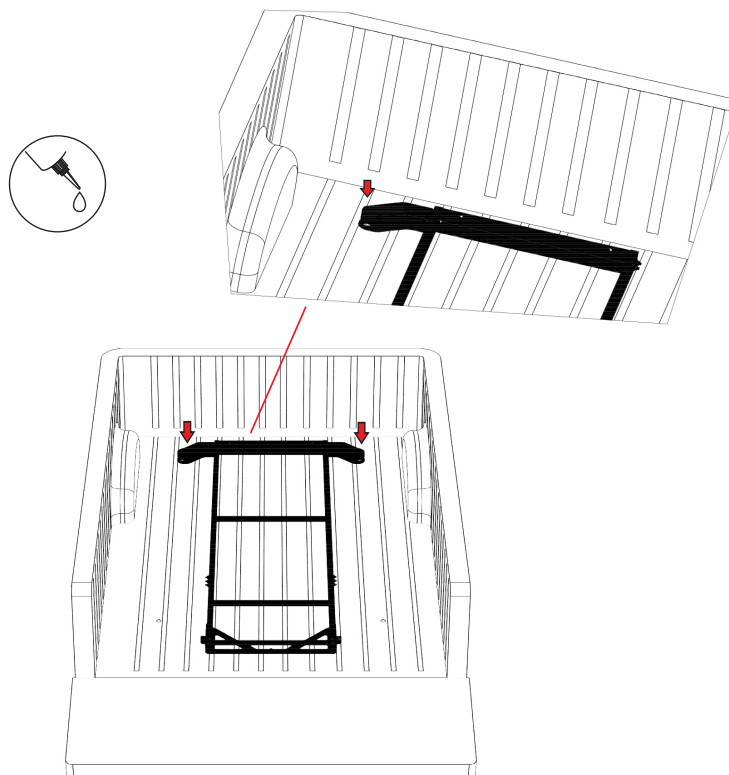

INSTALLATION

6 LOOSEN AND REMOVE CENTER BED BOLTS

Loosen and remove the center bed bolts using a ratchet with a T-55 torx bit.

Loosen per manufacturer specs. If your truck bed is equipped with a spray in liner you will need to cut around the head of each bolt with a utility knife to break the bed bolts free.



Discard the bed bolts.



DO NOT REMOVE ALL 4 BED BOLTS AT ONCE! Removal of all 4 bed bolts will allow the bed to move out of alignment. This will make it difficult to re-install the bed bolts.



T-55 TORX BIT



UTILITY KNIFE

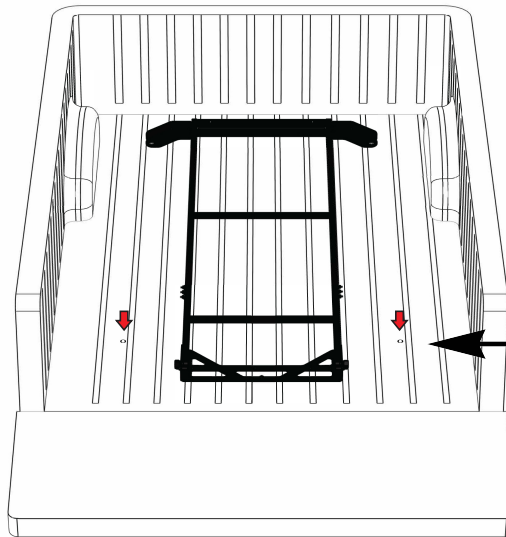

Bed bolt location depends on bed size.

7 REMOVE SPRAY IN LINER MATERIAL

If your bed is equipped with a spray in bed liner you must cut and remove the material around the bed bolt. A 3 1/2" x 3 1/2" square is sufficient.



UTILITY KNIFE

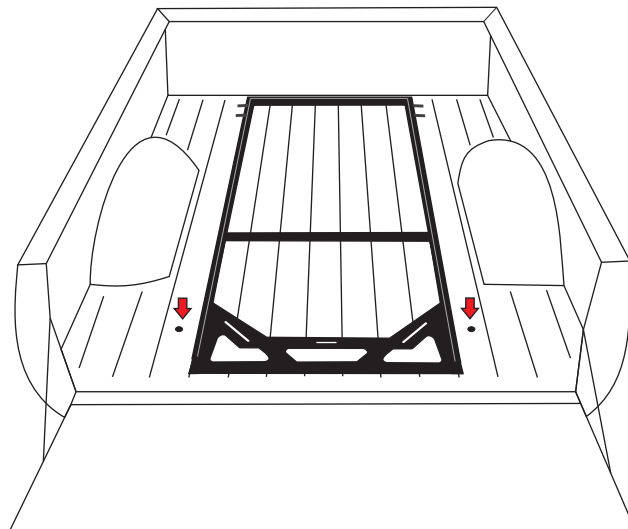

INSTALLATION

8 ATTACH REAR MOUNTING BRACKETS

Attach LEFT and RIGHT mounting brackets to the threaded studs affixed to each side of the base frame. Secure each bracket with two 5/16-18 serrated flange nuts & tighten with a 1/2" wrench.

 **TIGHTEN TO 21 FT. LBS.**

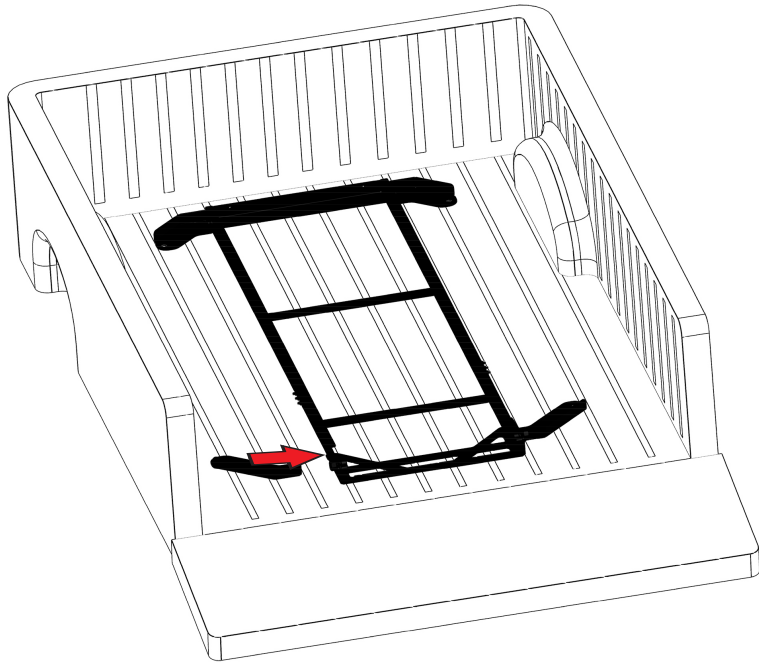
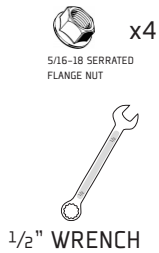

9 SECURE REAR MOUNTING BRACKETS TO THE BED

Apply a small bead of Loctite® 242 to the threads of the new bed bolts and secure both the LEFT and RIGHT mounting brackets directly to the bed.

 **TIGHTEN ALL FOUR BED BOLTS TO 59 FT. LBS. TO SECURE THE BEDSLIDE® IN PLACE.**

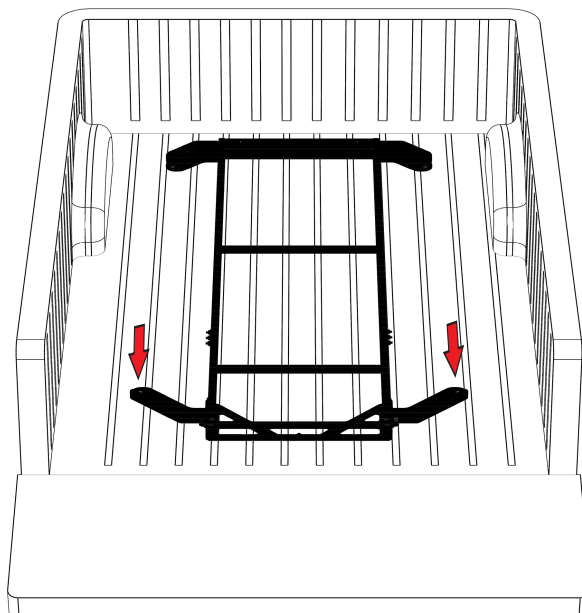
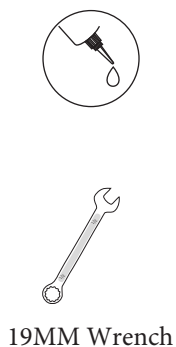

INSTALLATION

10 RE-INSTALL SLIDING TOP FRAME

Re-install the BEDSLIDE® top frame into the base by placing top frame over the rear bearings and sliding the frame forward to the stowed position. **This step will require 2 people to help lift!**

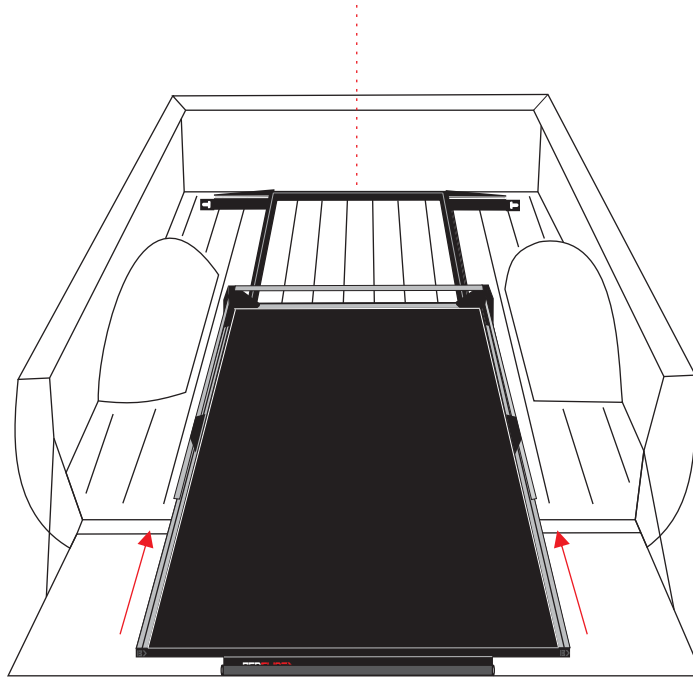
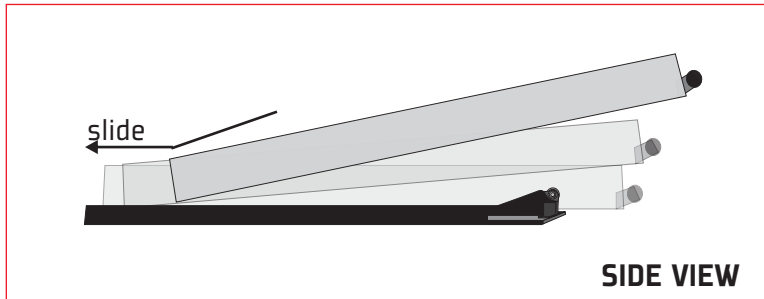

INSTALLATION

11 PROTECTIVE FILM REMOVAL

Pull a corner of the protective film and slowly pull it away from the die cut decals on each side of the tie down rails.



If the film comes up with a letter attached, position back in place and rub with a card such as a bank card or even your hand so the decal adheres to the surface of the tie down rail.



12 PROPER BEDSLIDE OPERATION

Proper operation will ensure many years of great service from your BEDSLIDE®.

Below are 3 easy steps for proper operation:

1. Unclip safety straps
2. Pull T-handle against the grab bar
3. With both hands firmly on the bar handle, slide to desired extension
4. Release handle and ensure it is in a locked position
5. Reverse steps to retract

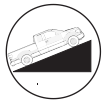

Do not operate on steep inclines!

Failure to do so can result in a runaway slide if the vehicle is on an incline. Utilize safety straps when BEDSLIDE is in retracted position.



Do not load the BEDSLIDE® beyond it's weight capacity!

Overloading the unit may cause damage to the steel frame or roller bearings.



Keep weight evenly distributed!

Improper loading may cause damage to the frame or roller bearings.



Do not drive in the extended position!

It is not safe and may cause damage to the latching pin or cause serious damage to the BEDSLIDE® frame.



Avoid fuel, oil, and chemical spills on the deck surface!

Pro longed exposure to fuel or chemicals will result in permanent stains on the deck surface. Wipe away immediately to avoid deck damage.