

RUBC

**RETRACTABLE  
UTILITY BED  
COVER**



**SECURE. ACCESSIBLE. RUGGED. THE CONTRACTOR WORKHORSE**

A job site necessity, our Retractable Utility Bed Cover is designed for service trucks. It's available as a manual, spring-action cover or with an electric motor for hands-free, remote operation.

**FEATURES**

- Available in manual and electric.
- Designed specifically for service body applications. Fits most 8', 9' and 11' models.
- Secure, attractive storage for tools and equipment.
- Made with tough, black, powder-coated aluminum panels, interlocked for strength and durability.
- Cover retracts into a front canister for full, easy access to the utility bed.
- Fully secure when closed even when the tailgate is unlocked.

**MANUAL COVER FEATURES**

- Heavy-duty spring helps retract the cover smoothly.
- Built-in pull strap engages the latch at 12" intervals.
- Mechanical weather hinge provides a tight seal between aluminum panels.
- Independent latch and lock handle system offset to driver side.



**ELECTRIC COVER FEATURES**

- Electromagnetic brake locks the cover in any position.
- Manual release mechanism allows opening during a power failure or emergency.
- Patented silicone weather hinge provides a tight seal between aluminum panels.
- Operating switch can be located in the cab, or an exterior locking compartment. Optional key fobs for hands-free remote operation are sold separately.

[pace-edwards.com](http://pace-edwards.com)

**IMPORTANT!** Due to the variances in manufacturing and aftermarket bedliners, all dimensions must be taken from the actual service body bed being used in the installation of the Utility Bed Cover. If there are any questions on any of the below please call us. We will help.

PLEASE TYPE OR PRINT NEATLY

CONTACT NAME:		COMPANY NAME:	
ADDRESS:			
CITY:	STATE:	ZIP:	
PHONE:	FAX:	EMAIL:	

### FITS MOST STANDARD 8' & 9' SERVICE BODY TRUCK BEDS

#### TAILGATE STYLE

The Utility Bed Cover vertical rail (that runs behind the tailgate) will extend all the way to the truck bed floor unless otherwise specified by the customer.

##### NON-SQUARE BOX DESIGN

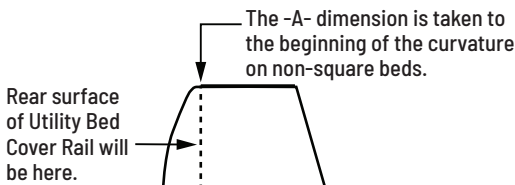

##### OUTSIDE MOUNTED TAILGATE

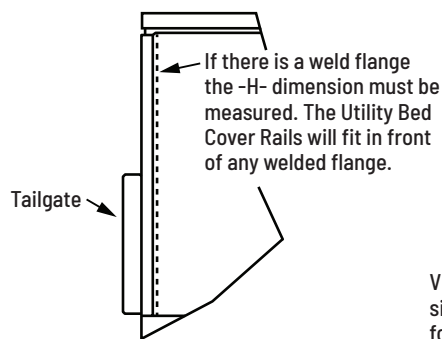

##### FLUSH MOUNTED TAILGATE

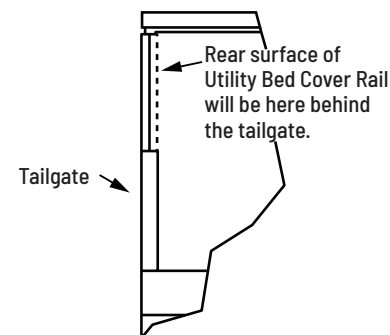

#### SPECIFY COVER TYPE & RAIL STYLE

**MANUAL COVER**

**ELECTRIC COVER**

**STANDARD RAILS**

**OPTIONAL EXPLORER RAILS**

(If the Front sill (-F-) is flush with the top of the truck box specify "N/A" or "0" in the dimensions below)

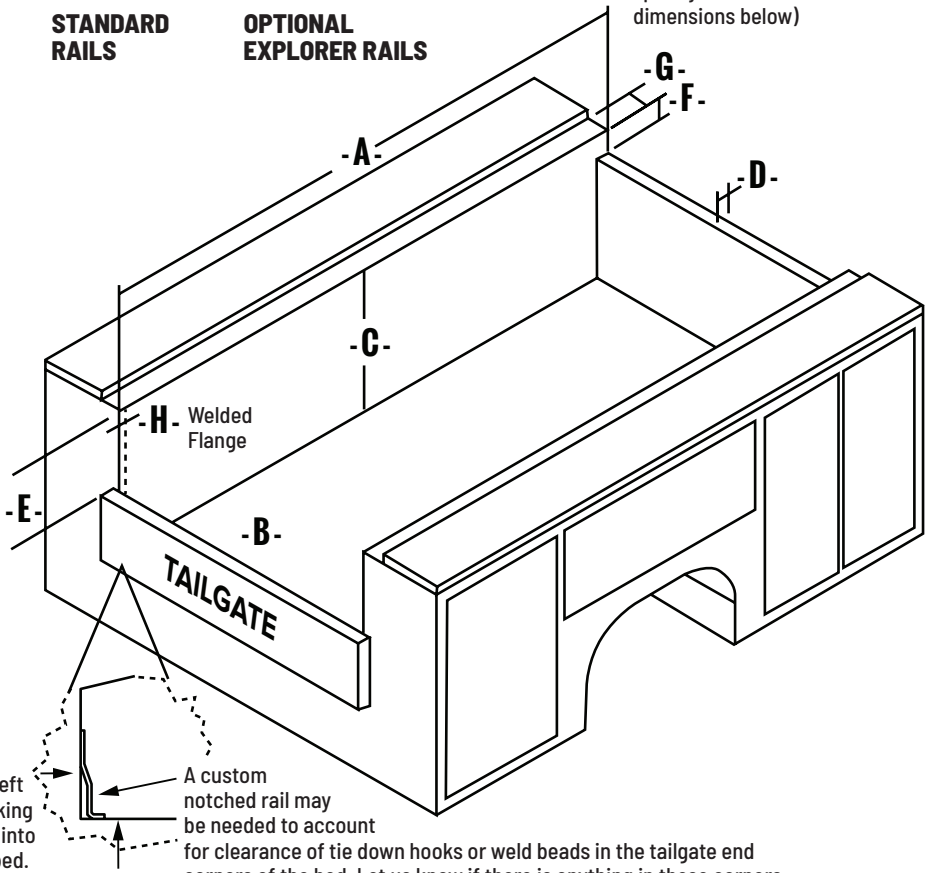

**MAKE ALL MEASUREMENTS IN INCHES ACCURATE TO WITHIN 1/16TH OF AN INCH.**

Please print neatly or type the dimensions below and fax back to us at (360) 237-1503.

<b>A</b>		<b>C</b>		<b>F</b>	
<b>B - Front</b>		<b>D - Sill</b>		<b>G</b>	
<b>B - Rear</b>		<b>E</b>		<b>H</b>	